

Metal Roofing and Siding Installation Guide

Installation details for Delta Rib™, Delta Rib™ III,
Nor-Clad®, Strata Rib® & 2½" Corrugated.

Metal Roofing Panels

Installation Guide for Delta Rib™, Delta Rib™ III, Nor-Clad®, Strata Rib® & 2½" Corrugated



Table of Contents

Section	Section
Introduction..... 2	Slope Transition - High to Low Slope..... 27
Minimum Recommended Tools & Equipment 2-3	Slope Transition - Low to High Slope..... 28
Delivery, Handling & Storage. 3	Chalet Gable Flashing 29
Safety Considerations 3	Adjustable Gable Flashing 30
Roof Preparation 4	Vent Flashing..... 31
Map of Typical Roof Conditions..... 5	Vent/Pipe Flashing Installation Procedure..... 32
Trim Locations..... 6	Skylight Flashing..... 33
Fastener Placement 6	Skylight Flashing (Side)..... 33
Fastener Selection 7	Skylight Flashing (Uphill Side)..... 34
Panel Installation..... 8	Skylight Flashing (Downhill Side) 35
Hip/Ridge Flashing..... 9	Procedure for the Installation of
Universal Ridge Termination 10	Skylight Flashings 36
Vented Ridge Flashing..... 11	Skylight Flashing Preparation 36-37
Vented Ridge Termination 12	Chimney Flashing 38
Valley Flashing 13	Chimney Flashing (Side) 39
Valley Termination..... 14	Chimney Flashing (Uphill Side) 40
Eave..... 15	Chimney Flashing (Downhill Side)..... 41
Eave Flashing Preparation 16	Valley Top End..... 42
Eave with Gutter 17	Valley Dormer 43
Gable Flashing..... 18	Panel End Lap 44
Gable/Ridge Transition..... 19	Sealing End Laps & Lapping the Hems..... 45
Gable Corner at Eave..... 19	Window/Door Trim Corner Wall Detail..... 46
Gable Flashing Preparation 20	Base Trim, Wall Step, Panel Top Wall Detail..... 47
Gable Flashing Preparation at Ridge 21	Inside Corner Wall Detail 48
Peak Flashing..... 22	Outside Corner Wall Detail..... 49
Vented Peak Flashing..... 23	
Sidewall Flashing 24	
Endwall Flashing..... 25	
Vented Endwall Flashing..... 26	

Introduction

In addition to weather tightness, long life, good looks and economy, ASC Building Product's Metal Roofing is designed with ease of installation as a primary consideration. This guide is intended to help the installer achieve a high level of quality in the finished product. Please do not hesitate to contact an ASC Building Products representative for assistance.

Important Notice

Be sure to read this manual in its entirety before beginning installation.

This manual is provided to the customers of ASC Building Products as a guide to assist in the installation of metal roofing. Use for any other purpose is prohibited. This manual remains the property of ASC Building Products.

These instructions contain suggested application procedures only and cannot replace the need for good common sense and experience. Responsibility for conformance to state and local building codes, as well as any other applicable project requirements rests with the installer, as does the responsibility to observe reasonable safety procedures.

ASC Building Products assumes no responsibility for any problems which might arise as a result of improper installation or any personal injury or property damage that may occur with the product's use.

Note:

- It is recommended that metal roofing be applied on roofs with a minimum slope of 3 inches per foot (3:12).
- * The details contained in this guide are shown over a plywood substrate. Details remain essentially the same for either a solid substrate (plywood/OSB or steel decking), spaced framing or intermittent support conditions with only the fastener type changing. Where spaced framing is used, perimeter supports for flashings must be considered.
- ** Each flashing part in this guide has been assigned a part number. Each part number contains one or two letters followed by one or two numbers, for example: (EW17). These part numbers have been provided for you to make ordering these flashing parts quick and easy.

Minimum Recommended Tools & Equipment

Screw Gun:

Clutch type screw gun with depth locating nose piece allowing variable torque settings is recommended to insure proper installation of the screws. The following sockets will be required: ¼" and/or ⅝" hex.

Snips:

For miscellaneous panel and flashing cutting requirements. Three pairs of snips will be required for left edge, right edge, and centerline cuts.

Electrical Metal Shears:

Used for general metal cutting, such as at the hips and valleys

Note:

Some erectors prefer to use circular power saws with metal cutting abrasive blades. While the use of power saws may be faster, there are some disadvantages that must be considered:

- (1) *The edges of metal that have been saw cut are jagged and unsightly, and are more likely to rust than sheared edges.*
- (2) *Saw cutting will leave small particles of metal on the panel surface that will rust and damage the panel finish if not completely removed.*

Chalk Line:

Used to assist in the alignment of panels, flashings, etc

Neoprene Foam Tape:

⅛" x ¼" roll of tape used for installation of inside and outside profile closures and panel side laps.

Butyl Mastic Tape:

⅞" x ½" roll of tape used for prevention of water infiltration in flashing to sheet metal applications.

Caulk:

Butyl or urethane sealant used to inhibit water infiltration.

Caulking Gun:

For miscellaneous caulking and sealing to inhibit water infiltration.

Blind Rivet Hand Tool:

Used for miscellaneous flashing and trim applications.

Marking Tools:

Indelible markers, pencils, or scratching tools.

Minimum Recommended Tools & Equipment (Con't)

Scratch Awl:

Used to mark the steel.

Utility Knife:

Used for miscellaneous cutting.

Electric Drill:

Used to drill holes such as those required for rivet installation.

String Line:

Used for general alignment and measuring.

Tape Measure:

25 foot minimum (another 50 ft. is handy).

Locking Pliers:

Standard and “Duckbill” style for miscellaneous clamping and bending of parts.

Delivery, Handling and Storage

- Always check the shipment upon delivery. Check for damage and check material quantities against the shipping list. Note any damaged material or shortages at the time of delivery.
- Handle panel bundles and individual panels with care to avoid damage. Longer bundles and panels may require two or more “pick points” properly spaced to avoid damage that can result from buckling and/or bending of the panels. Request a copy of the Long Length Handling Instructions and diagrams from ASC Building Products customer service as required.
- Improper storage of product can result in damage to the finish known as Wet Stack Staining. Store the panels and other materials in a dry, well ventilated area and away from traffic. Elevate one end of the bundle to prevent moisture from settling on the panels. Be sure that air will be able to circulate freely around the bundles to avoid the build-up of moisture. Cover the product with a tarp and allow for air circulation around and under the tarp and bundle of material. Minimize field storage of material. Contact with wet cement should be avoided. Damage due to improper storage is not the responsibility of ASC Building Products.
- Painted panels are shipped with a protective plastic sheeting or a strippable film coating between all panels. Remove any strippable film coating prior to installation and in any case, do not allow the strippable film coating to remain on the panels in extreme heat, cold, or in direct sunlight or other UV source.
- Wear clean cotton gloves when handling unpainted ZINCALUME®-coated panels or flashings to avoid discoloration. Rollforming die marks (which appear black), particularly at bends, will be visible.
- Wear clean, non-marking, soft soled shoes when walking on the panels to avoid shoe marks or damage to the finish. Do not step on the panel seams or ribs. Step only in the flat area of the panel.

Safety Considerations

- **Never use unsecured or partially installed panels as a working platform.**
Do not walk on panels until they are in place on the roof and all of the fasteners attaching the panels to the roof have been installed.
- **Metal roofing panels are slippery when wet, dusty, frosty or oily.**
Do not walk on a metal roof when any of these conditions are present. Wearing soft soled shoes will help minimize slipping and help prevent damage to the painted surfaces.
- **Do not walk on the panel seams or major ribs.**
When walking on the fully installed roof panels, be sure to step only in the flat areas of the panels.
- **Always be aware of your position on the roof relative to your surroundings.**
Take note of the locations of roof openings, roof edges, equipment, co-workers, etc.
- **Always wear proper clothing and safety attire.**
Wear proper clothing when working with sheet metal in order to minimize the potential for cuts, abrasions, and other injuries. ASC Building Products recommends safety glasses and gloves.
- **Use care when operating electrical and other power equipment.**
Observe all manufacturer’s safety recommendations.
- **Roof installation on windy or stormy days can be dangerous.**
Avoid working with sheet metal products on windy or stormy days.

Metal Roofing Panels

Installation Guide for Delta Rib™, Delta Rib™ III, Nor-Clad®, Strata Rib® & 2½" Corrugated



Roof Preparation

ASC Building Products Metal Roofing can be used in both new construction and retrofit roofing applications. We recommend the installation of metal roofing over a continuous rigid substrate such as plywood/OSB, or over spaced supports. Contact ASC Building Products for additional information.

The following steps need to be taken to prepare the roof for installation of metal roofing panels:

New Roofs:

1. Make sure there are no nails or other objects protruding from the substrates that might puncture the underlayment or the roof panels. Clean all debris from the roof.
2. Check all details for possible roof penetrations which must be added to the deck prior to roof panel installation.
3. Cover the entire roof deck with a minimum of 30 lb asphalt-saturated felt paper. Some synthetic underlayments may be used in place of felt with ASC Building Products' roofing. Installer must ensure they meet the minimum standards of 30 lb felt and that the underlayment manufacturer has approved them for use with metal roofing. For applications over spaced framing other types of moisture barriers may be required. For Class A fire resistance, see notes below. For installation begin at the eave and roll the underlayment horizontally (parallel to the eave). Allow each consecutive course to overlap the previous one 3 inches. Overlap the ends a minimum of 6" (See illustration #1). Areas of underlayment that have torn should be replaced or repaired prior to installation of the metal roof.

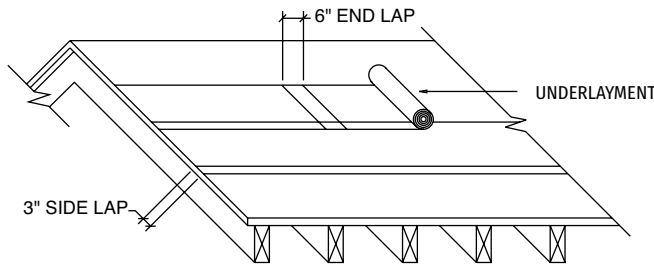

Illustration No. 1

Constructions Requiring Class 'A' Fire Resistance:

Panel: ASC Building Products' steel roof panels.

Barrier Sheet (one of the following):

- GAF VersaShield® Underlayment
- Firestone GLAD-GARD™ SA-FR
- Polyglass Polystyck® XFR
- Georgia-Pacific DensDeck® Roofboard

Additional Ply Sheet (optional): Any UL Classified Type G1, G2 or G3 base/ply sheet, Type 15, 20 or 30 felt or UL Classified Prepared Roofing Accessory (TGDY) or ASC Building Products' "AEP Span Underlayment HT".

Substrate: 15/32" min. plywood or 7/16" min. OSB

Notes:

- Obey all local code requirements.
- Class A assembly requirements noted above per UL listing TGFU.R21182. Refer to UL listing for specific construction limitations.

4. Place an alignment line along the gable end where the first roof panel will be installed. **This line must be parallel to the gable edge of the roof deck and square with the eave line.** Check the roof for squareness by making a 3' line across the eave. (See illustration #2).

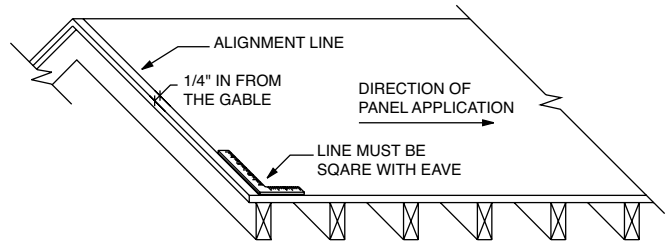

Illustration No. 2

Completing the 3' x 4' x 5' triangle should place the 4' edge of the triangle parallel with the gable. The first roof panel will be placed parallel with this line. Slight variations or out-of-square conditions up to 3" can be covered by the gable trims shown on page 18.

5. It is very important to measure the entire length of the roof from gable to gable. Correct placement of the panels will allow the panel's ribs on each side to be covered by the gable flashing shown on page 18. This will create a symmetrical appearance on both gables. Should this be impractical, the adjustable gable detail on page 30 can be used.

Note:

In areas where snow, ice, and heavy rain conditions exist, a high temperature cold-applied rubberized underlayment, like AEP Underlayment HT, should be used in lieu of felt in the valleys. Felt on the remainder of the roof will lap over the membrane where the two meet. See Valley page 13.

Existing Roofing:

Some jurisdictions will allow reroofing over existing roofing without the need for tearoff. Check with your local codes or building department for your specific requirements.

For best results, Roofing requires a relatively smooth and flat substrate. Application over rough and/or uneven surfaces is not recommended, for example, wood shingles. If the roof is to be stripped down to the existing decking, follow the procedures for new roofs on page 4. Be sure to check the existing roof and repair any damaged areas prior to installation of the new roof system.

Note:

Do not apply metal roofing over roofs with structural damage or trapped moisture.

The following steps should be taken when installing ASC Building Products' Metal Roofing over existing roofing:

1. Inspect the roof for damage and make the necessary repairs to achieve a flat plane for the metal roof panels. Wood shingles should be removed.
2. Secure any warped or loose roofing.
3. Make sure that there are no nails or other objects protruding from the roof that might puncture the new underlayment or the new roof panels.
4. Remove all moss and other debris from the roof.
5. Cut off any overhanging roofing flush with the roof deck and remove all hips, ridge caps, and penetration flashings.
6. Metal debris/shavings should be removed from the roof progressively and daily to prevent immediate corrosion and scratching of the top coat.
7. Follow the directions on page 4, #2 through #5 on roof preparation.

Map of Typical Roof Conditions

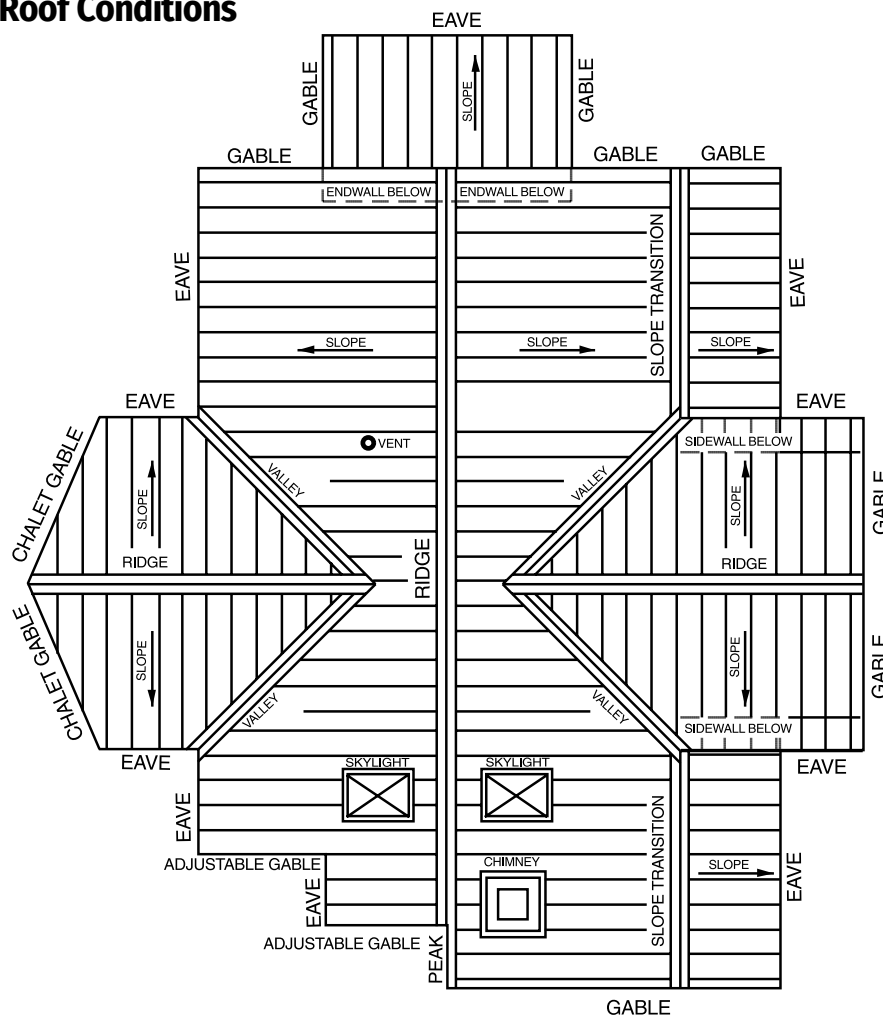

For suggestions on how to trim flashings in the different areas, please refer to the following pages:

Flashing	Page(s)	Flashing	Page(s)
Adjustable Gable.....	30	Peak	22
Chalet Gable	29	Pitch Transition.....	27-28
Chimney	38-41	Ridge	9, 11
Eave.....	15-16	Sidewall Flashing	24
Endwall	25-26	Skylight.....	33-37
Gable	10, 12, 18-21	Valley.....	13-14, 42-43
Gutter	17	Vent.....	31-32

Metal Roofing Panels

Installation Guide for Delta Rib™, Delta Rib™ III, Nor-Clad®, Strata Rib® & 2½" Corrugated



Trim Locations

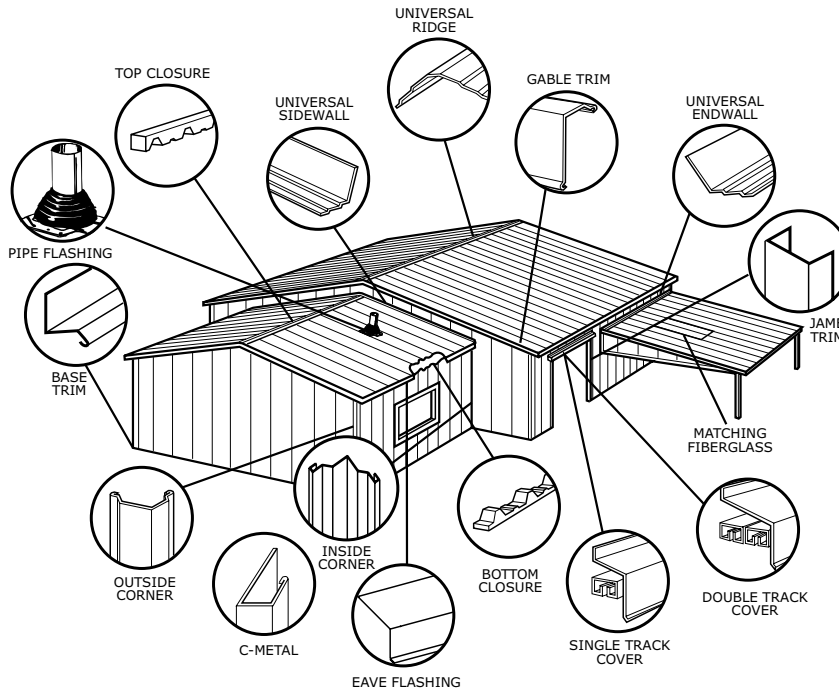

Fastener Placement

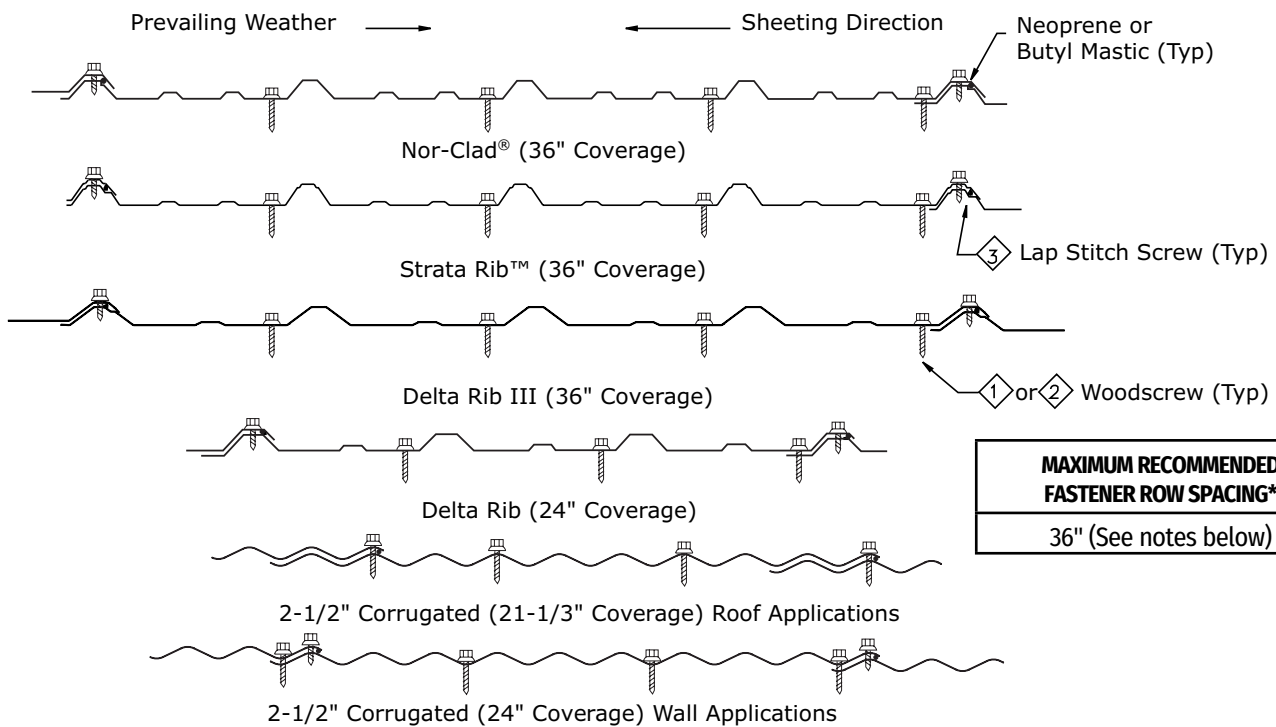













Notes:

Lap panels away from prevailing weather. Use only those accessories specifically designed for use with this product. Use only galvanized or ZINCALUME®-coated fasteners. Isolate roofing and flashings from contact with dissimilar metals. Fastener selection will vary based upon - see chart on following page. The use of neoprene or butyl mastic tape along the sidelaps, as shown above, is always recommended for roofs. Lap stitch screws should be placed at 16" o.c. maximum.

*The maximum recommended fastener row spacing is based on 2018 IBC/IRC 115 mph wind speed and an exposure rating of "B" (protected) for typical buildings. Refer to IAPMO-UES Building Code Compliance Report #ER-0550 for a more complete list of panel attachments and performance data. More efficient panel attachment patterns may be available.

Fastener Selection

Fastener #	Description	Use
	 No. 9 x 1", 1½", 2", 2½", 3" Wood Screw ¼" Hex Head	Panel to dimensional lumber
	 No. 14 x 1", 1½" Wood Screw ⅝" Hex Head	Panel to plywood/OSB minimum 7/16" thick.
	 No. 12 x ¾" Stitch Screw ¼" Hex Head (compatible with No. 9 Wood Screw)	Trim and side lap attachments.
	 No. 14 x ⅞" Lap Self Driller ⅝" Hex Head (compatible with No. 14 Wood Screw)	Trim and side lap attachments.
	 Stainless Steel Rivet ⅛" x ⅛"	Trim-to-trim or trim-to-panel attachments.
	 No. 12 x 1", 1½", 2", 2½" Self Driller ⅝" Hex Head	Panel to purlin or deck attachments

Notes

- The table above shows the metal roofing panel fasteners provided by ASC Building Products. Refer to the panel installation, flashing details, and fastener placement pages of this manual for specific fastener usage. See page 6 for fastener spacing.
- Panel attachment screws must be long enough to penetrate through the roof decking at least ⅜", or penetrate into solid lumber at least one inch.
- All screws must be coated to provide protection against corrosion.
- Exposed fasteners should have sealing washers and be the same color as the parts they attach.
- Roofing nails will also be required, but are not furnished by ASC Building Products. They are typically used to temporarily hold a flashing in place that needs to be installed prior to the panels.
- Screws must be properly driven to ensure proper seal and holding strength. Do not under drive or overdrive the screws. Recommended drill speed is 2000 rpm. Use of a depth-sensing nosepiece will aid in properly driving screws.

Proper Installation of Gasketed Fasteners

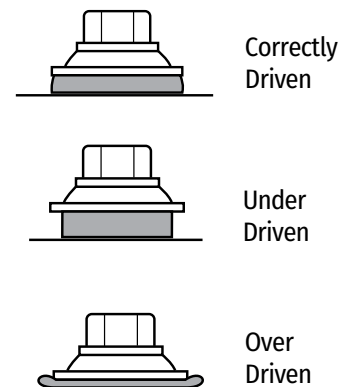

Metal Roofing Panels

Installation Guide for Delta Rib™, Delta Rib™ III, Nor-Clad®, Strata Rib® & 2½" Corrugated



Panel Installation

GENERAL

Study the details section of this manual prior to the installation of the panels. Pay close attention to the following:

- Flashings that need to be installed prior to the panels include Valley, Eave, Vented Eave, Adjustable Gable and Chalet Gable.
- Apply sealant or mastic tape to the pre-installed flashings as shown in the detail section of this manual.

PROCEDURE

1. Install eave trim, valley trim and inside closure prior to panel installation.
2. Align the edge of the first panel with the alignment line constructed along the start gable. (See page 4 item 4 and illustration #3 below). Allow the panel to overhang the eave 1" minimum.
3. Check the downhill end of the panel. If the panel length is correct, the panel should overhang 1" past the eave trim as shown below in illustration #4. Also, the panel should not extend past the centerline of the ridge. (See page 9)
4. After the first panel is properly aligned, fasten per the fastener placement and spacing guidelines on page 6.
5. Lay down the second and third panels, checking alignment, making sure they are square. This will ensure that a sawtooth effect at the eave and ridge is avoided.
6. Metal debris/shavings should be removed from the roof progressively and daily to prevent immediate corrosion and scratching of the top coat.

ILLUSTRATION #3

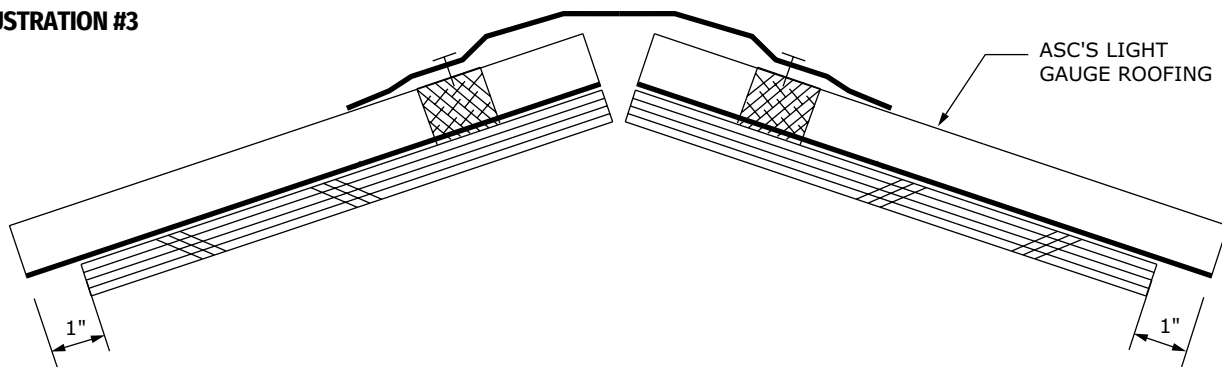
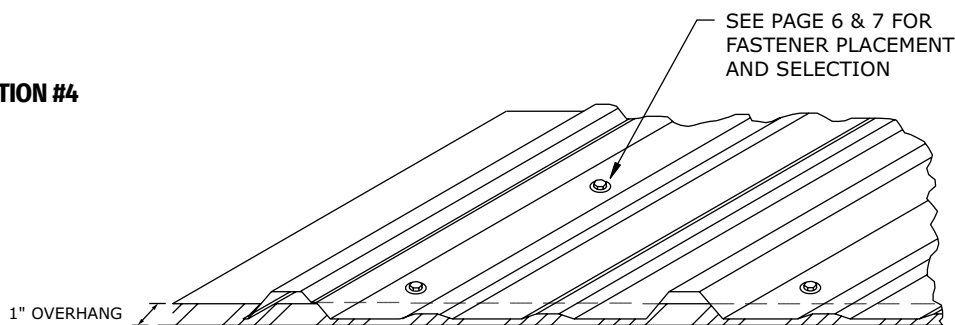
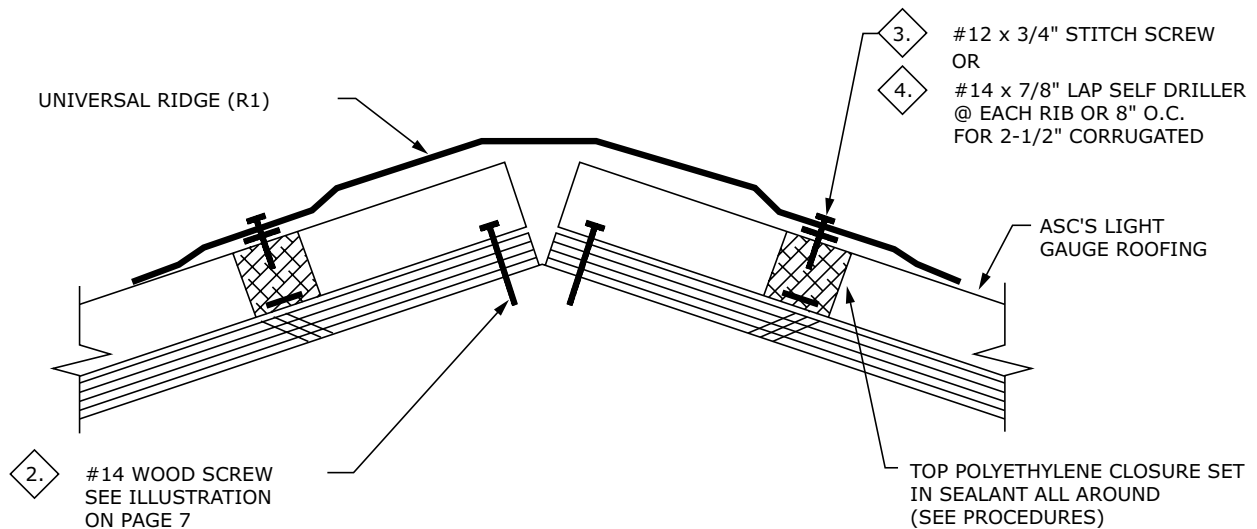
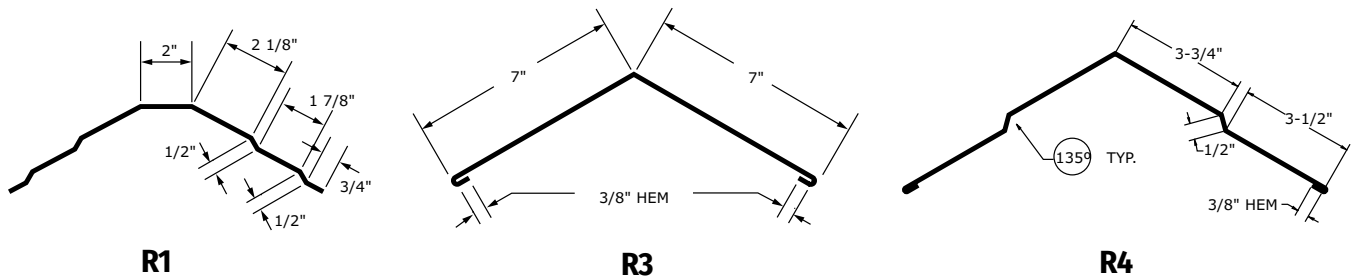

ILLUSTRATION #4



Hip/Ridge Flashing



Note: The gable flashing must be installed prior to installation of the ridge (see page 18).

Procedures

- Caulk the bottom and sides of the polyethylene closure. Set the closure as shown above and caulk the top. The closure is optional if the panel is turned up and caulked at the sides near the rib.
- Fasten the ridge cap using stitch screw at each rib or 8" o.c. for 2-1/2" Corrugated.
- Close the ends of the universal ridge cap by cutting and folding material at each end. Fasten with rivets. (see page 10)
- Caulk, lap and rivet sequential ridge flashings. (see page 45)

Note: "R1" is a universal hip/ridge. A standard hip/ridge, "R3 & R4", is also available.

Metal Roofing Panels

Installation Guide for Delta Rib™, Delta Rib™ III, Nor-Clad®, Strata Rib® & 2½" Corrugated



Universal Ridge Termination

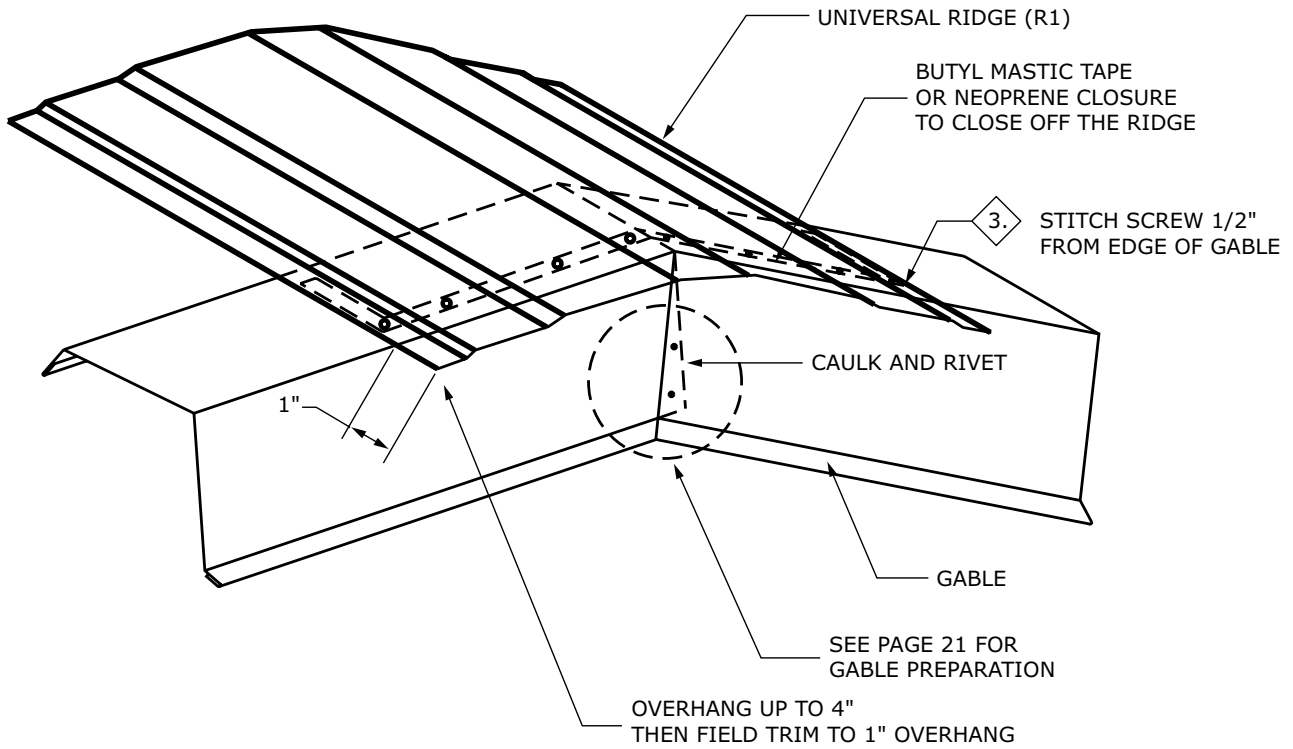

Vented Ridge/Hip Flashing

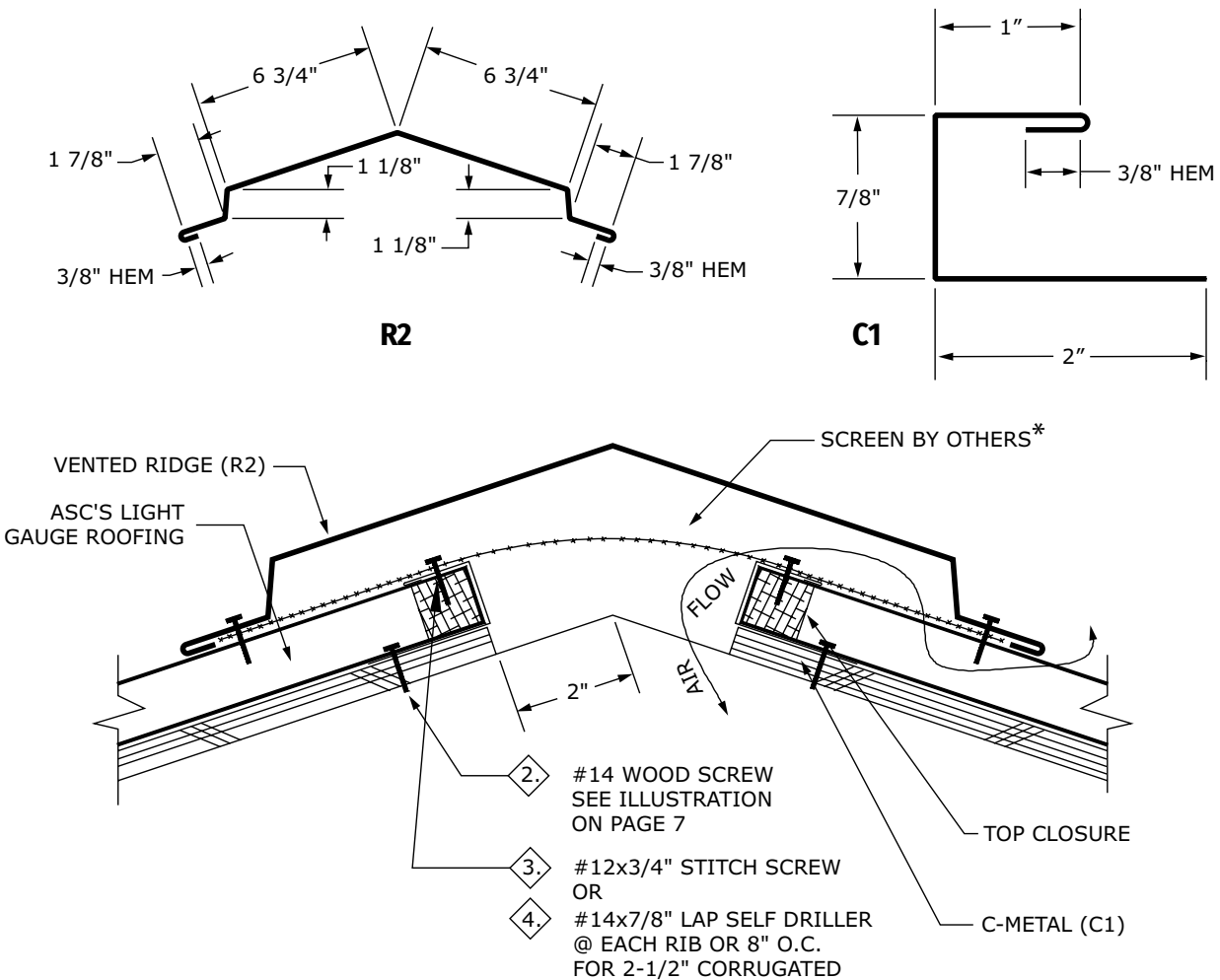

*Consult applicable building codes to ensure ridge vent screening meets minimum material requirements.

Procedures

- Substrate should be held back 2" from each side of the ridge.
- Attach the screen at each panel rib sandwiching the top closure in place. Ensure screen is pulled tight to avoid sagging.
- Fasten the vented ridge using stitch screw at each rib or 8" o.c. for 2-1/2" Corrugated.
- Caulk, lap and rivet sequential flashings. (see page 45).
- Close the ends of the ridge cap by cutting and folding material at each end. Fasten with rivets and caulking joints. (see page 12).
- Slopes greater than 6:12 may require special ridge dimensions.
- For SFS VistaVent® or ProfileVent® alternate venting, use flashing detail on page 9 and substitute closure with vent material.

Note: The gable flashing must be installed prior to installation of the ridge (see page 18).
 The screening shown creates a barrier for insects and birds while allowing for ventilation.
 For snow and heavy rain environments, please inquire about other optional Vented Ridge details.

Metal Roofing Panels

Installation Guide for Delta Rib™, Delta Rib™ III, Nor-Clad®, Strata Rib® & 2½" Corrugated



Vented Ridge/Hip Termination

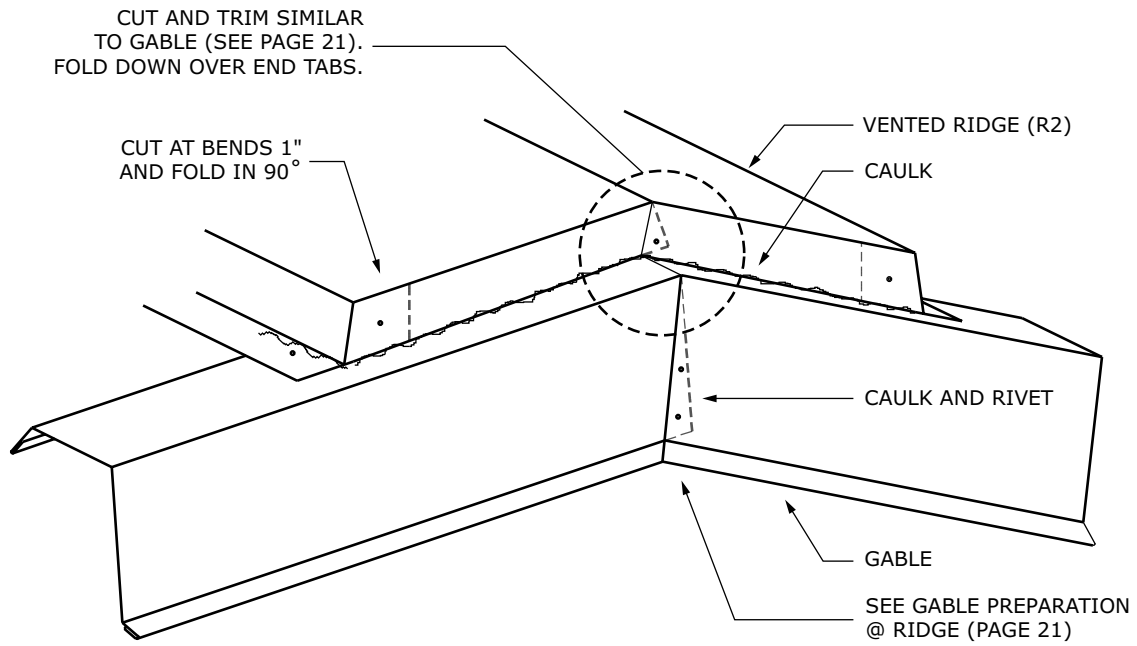

Valley Flashing

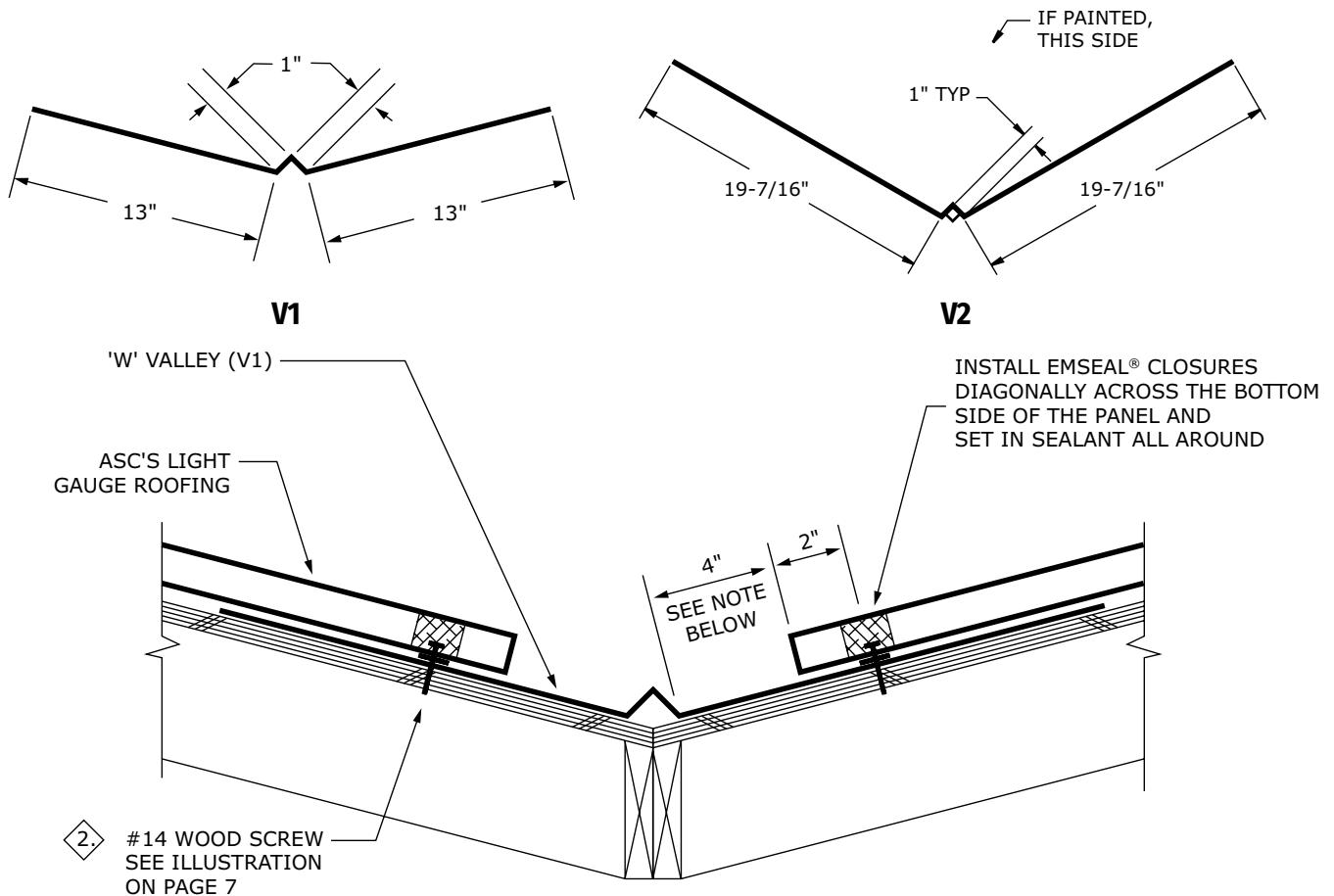

Procedures

- Place a second layer of 36" roof underlayment in the valley center line with 18" of roof underlayment on each side.
- Starting at the low end, trim and place the valley flashing so it overhangs the eaves 1". (see page 14)
- Caulk and lap the subsequent valley flashings a minimum of 8".
- Typical polyethylene closures cannot be installed diagonally across a mitre cut panel. At mitre cuts, use universal Emseal® closures parallel to the center of the valley.
- Field cut the panels holding a minimum of 4" back from the valley as shown. Larger valleys without the center "V", may be required in snow country installations.
- Install the panels over the valley flashing using #14 wood screws through the Emseal closure strip.

Space panel fasteners no further apart than as shown on Page 8.

- When valleys are required, install sidelap neoprene or butyl mastic tape along the sidelap a minimum of 10" up from the panel edge.

Note: In areas where snow, ice and heavy rain conditions exist, panels may need to be held back more than 4" and the valley flashing overall width must be increased. A high temperature cold-applied rubberized underlayment should be used extending at least 3' up from the center of the valley on each side.

Note: Refer to applicable building codes to ensure roof valley construction meets code requirements. Certain jurisdictions, like wildfire prone areas, may require different construction methods or materials.

Metal Roofing Panels

Installation Guide for Delta Rib™, Delta Rib™ III, Nor-Clad®, Strata Rib® & 2½" Corrugated



Valley Termination

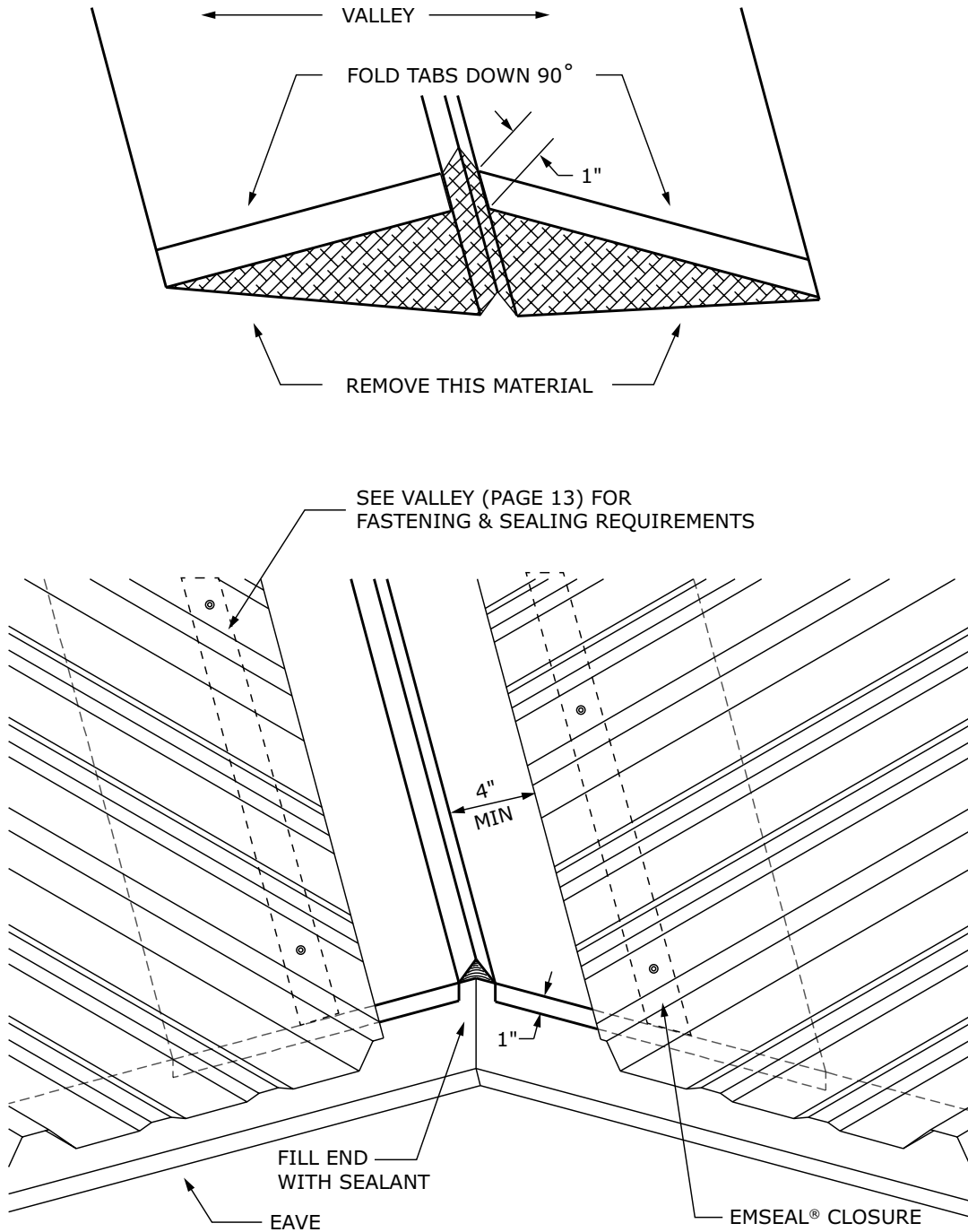

Eave and Vented Eave Flashings

This flashing must be installed prior to the panels.

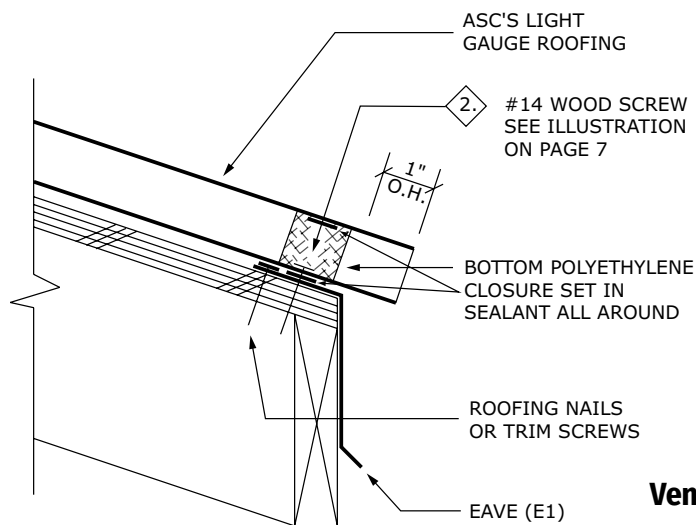
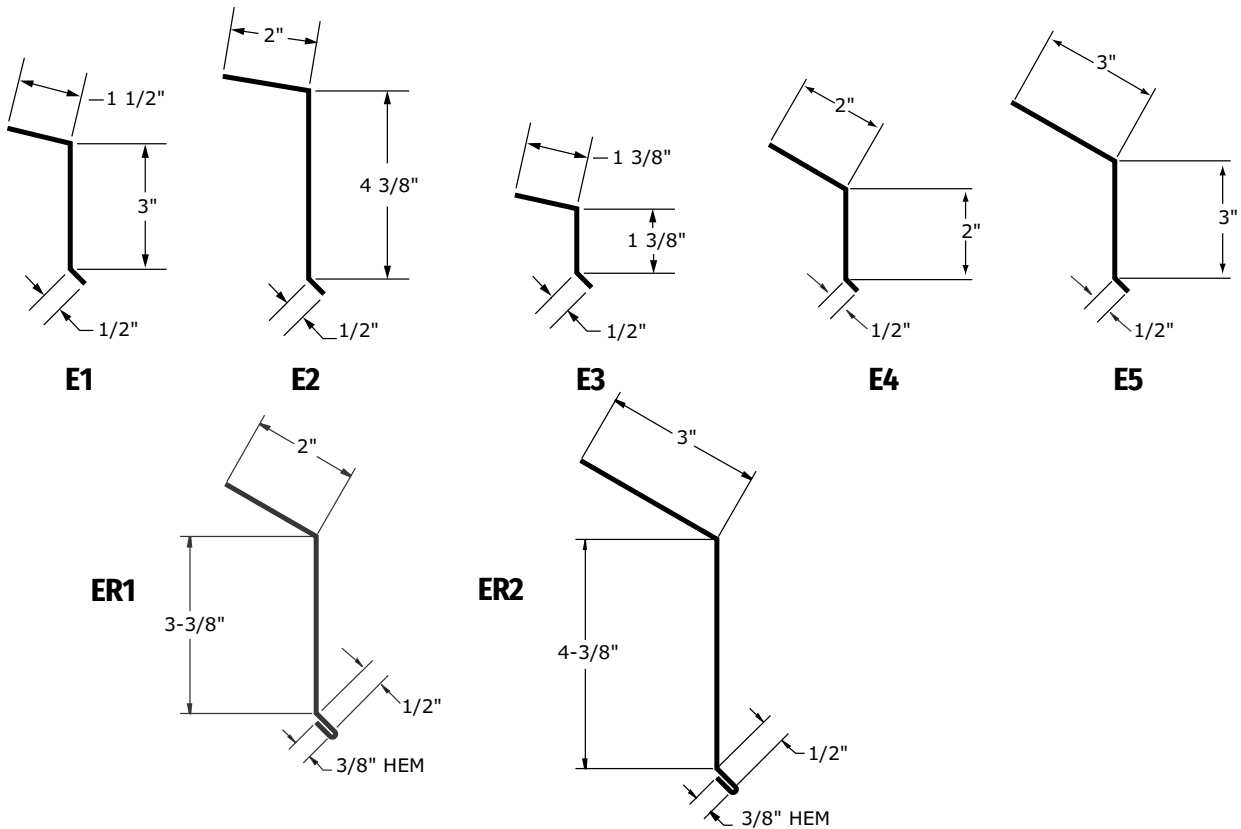

Vented Eave

Procedures

- Attach the eave flashing using roofing nails or trim screws evenly spaced to temporarily secure flashing prior to installing panels.
- Caulk and lap the flashing a minimum of 3". (see page 45)
- Panels should overhang the eave 1" minimum.

Metal Roofing Panels

Installation Guide for Delta Rib™, Delta Rib™ III, Nor-Clad®, Strata Rib® & 2½" Corrugated



Eave Flashing Preparation

Use this flashing where eave meets gable

Note: Length of eave must allow 1" to extend past gable fascia.

STEP 1

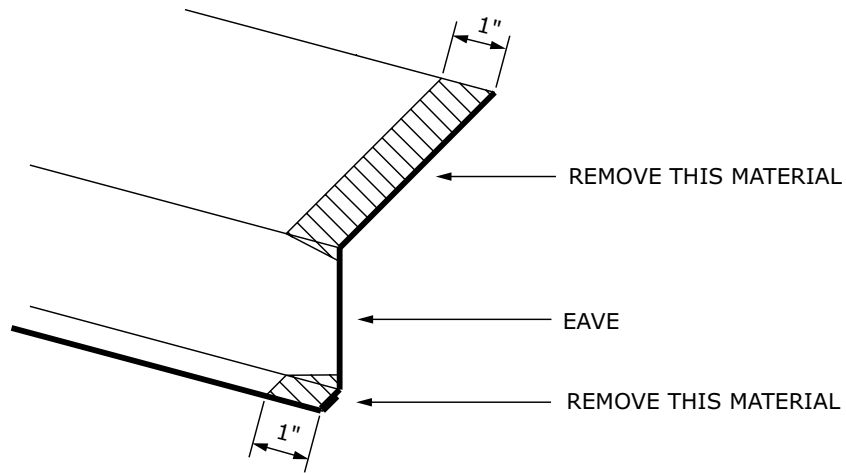

STEP 2

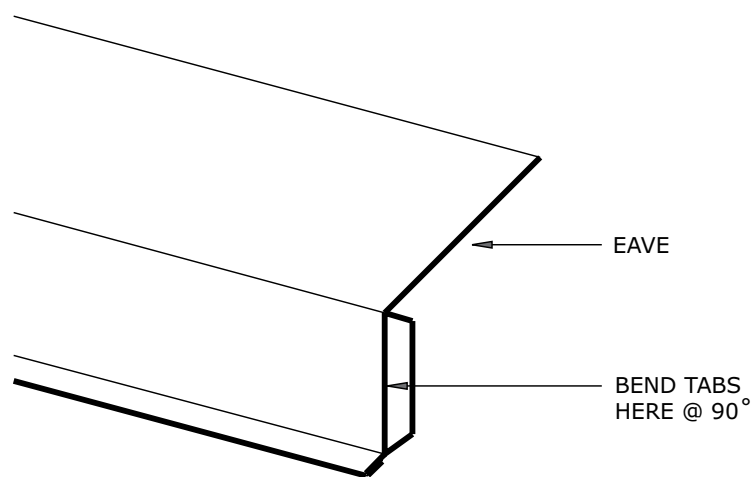

Eave With Gutter

Note: This flashing must be installed prior to the panels.

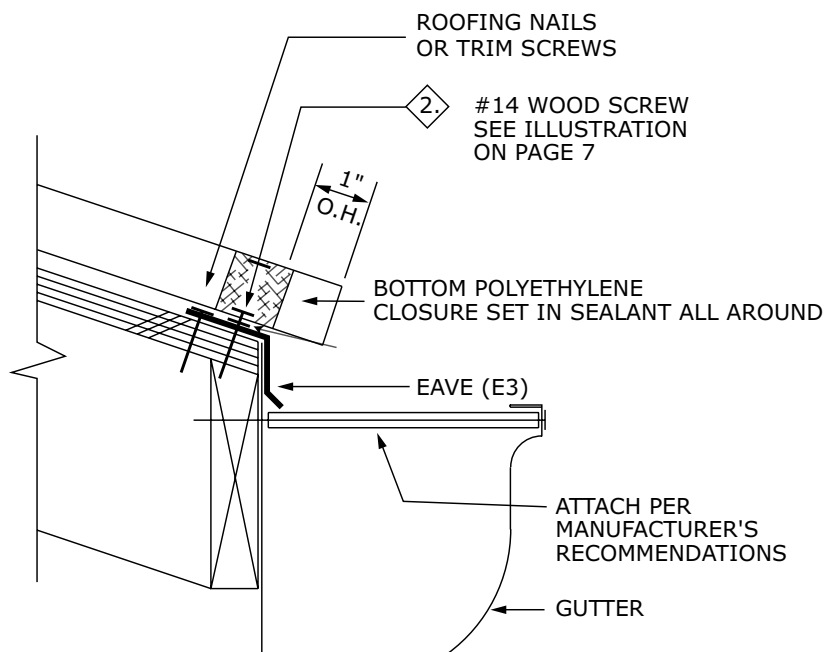
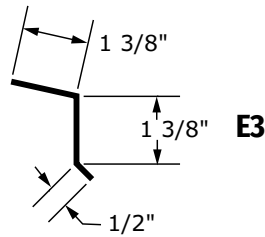

Procedures

- Underlayment should be installed over top of eave (E3) flashing (underlayment not shown).
- Temporarily attach eave flashing using roofing nails or trim screws to secure flashing prior to installing panels.
- Caulk and lap the flashing a minimum of 3". (see page 45)
- Panels should overhang the eave a minimum of 1".
- ASC Building Products recommends that a licensed gutter contractor install gutters.

Metal Roofing Panels

Installation Guide for Delta Rib™, Delta Rib™ III, Nor-Clad®, Strata Rib® & 2½" Corrugated



Gable Flashing

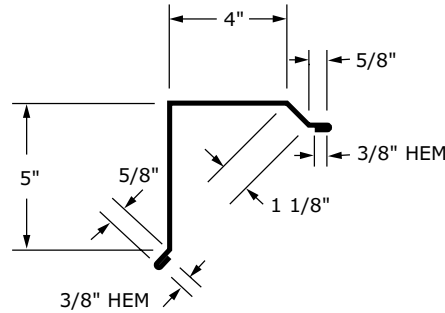

G1

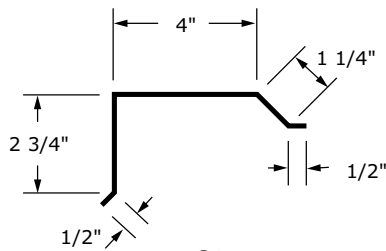

G3

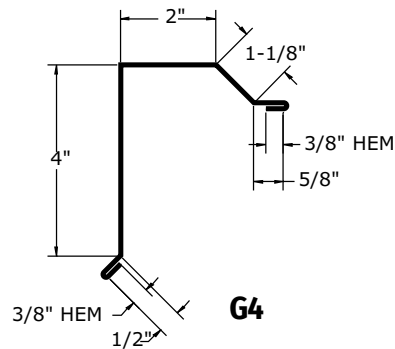

G4

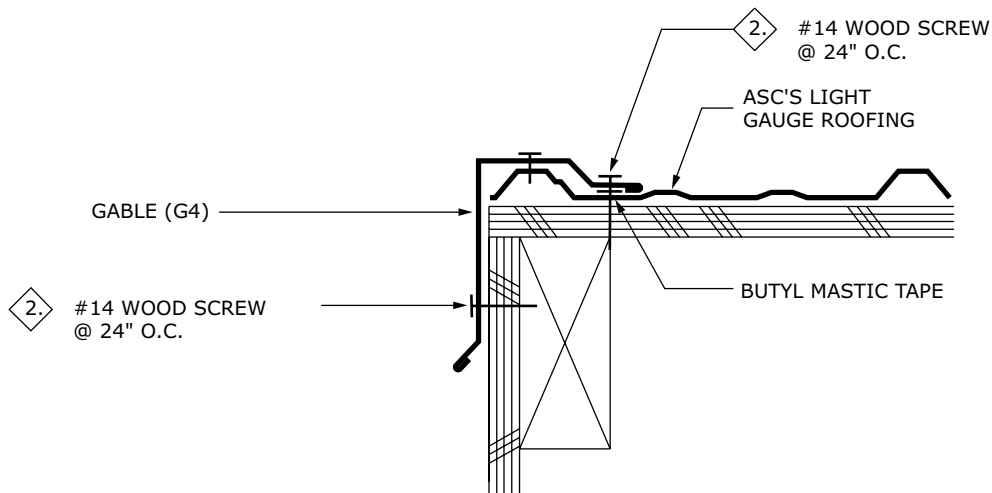

Procedures

- Place the first roof panel according to the instructions on pages 4 and 8.
- Place butyl mastic tape along flange of gable trim as shown.
- Install the gable flashing by placing it firmly over the panel. Use color matched wood screws at 24" o.c. to attach gable trim to the panel and substrate.
- Caulk and lap the flashing a minimum of 3". (see page 45)
- Mitre cut the flashing at the peak to join each side at the ridge. (see page 21)
- Snip and fold the gable at the eave to close the end. Use rivets to fasten.

Notes: "G1" is a standard gable. Narrower gables, "G3" and "G4", are also available.

Gable/Ridge Transition (similar to Endwall)

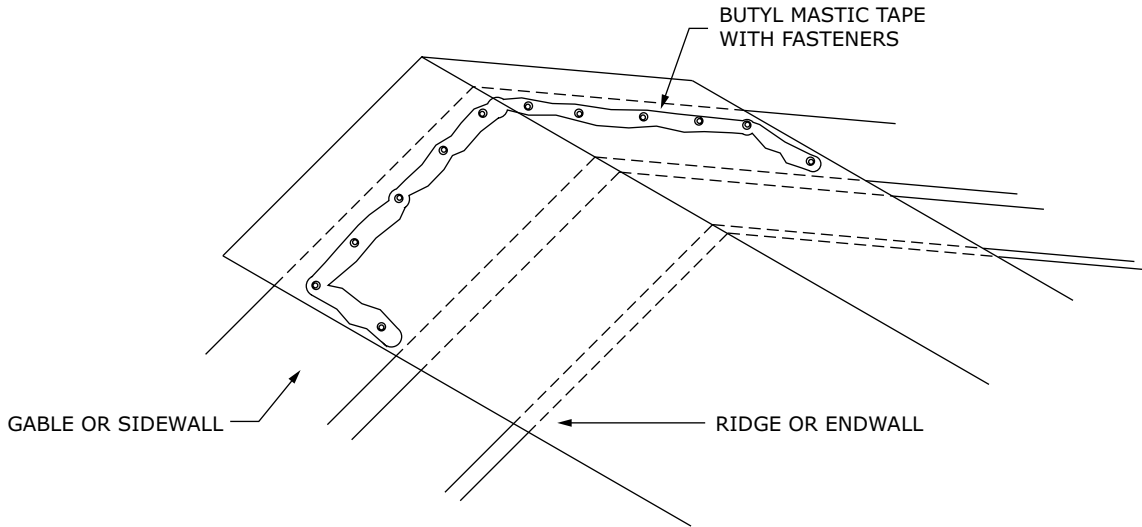

Gable Corner at Eave

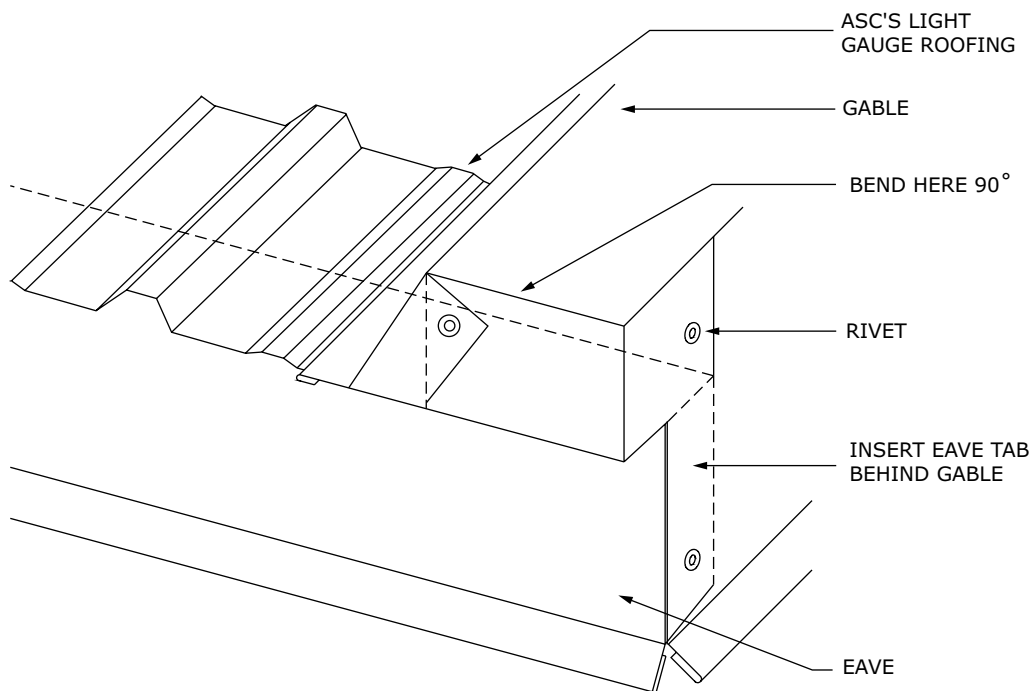

Metal Roofing Panels

Installation Guide for Delta Rib™, Delta Rib™ III, Nor-Clad®, Strata Rib® & 2½" Corrugated



Gable Flashing Preparation

Roof Pitch	Dimension
3:12	2"
4:12	1⅞"
5:12	1⅚"
6:12	1⅝"
12:12	⅝"

STEP 1

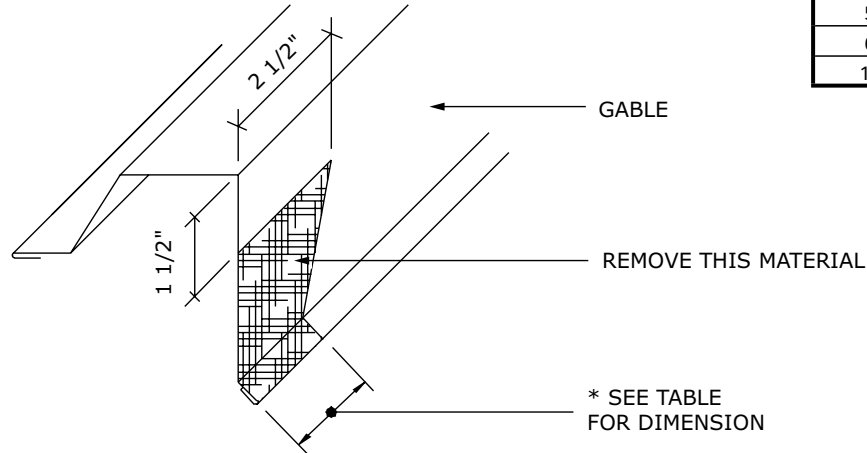

STEP 2

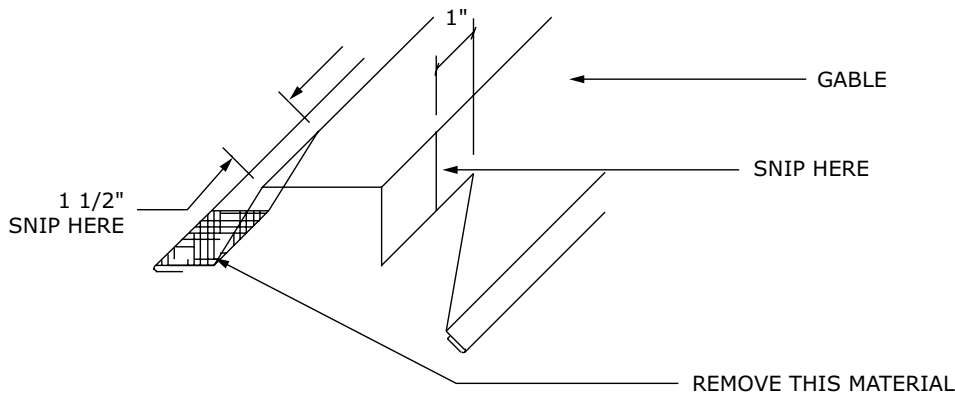

STEP 3

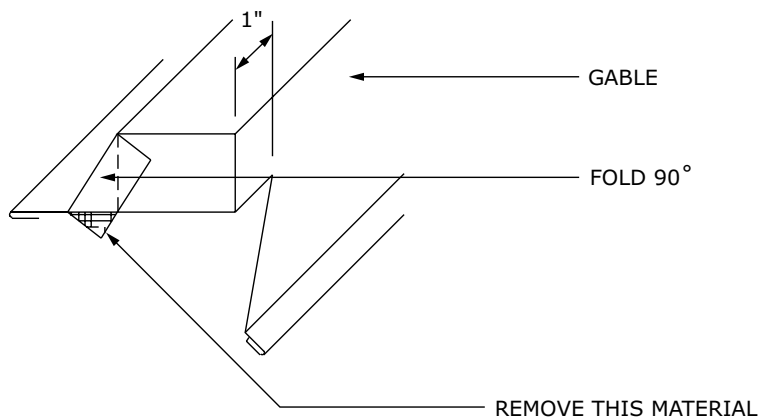

Gable Flashing Preparation at Ridge

STEP 1

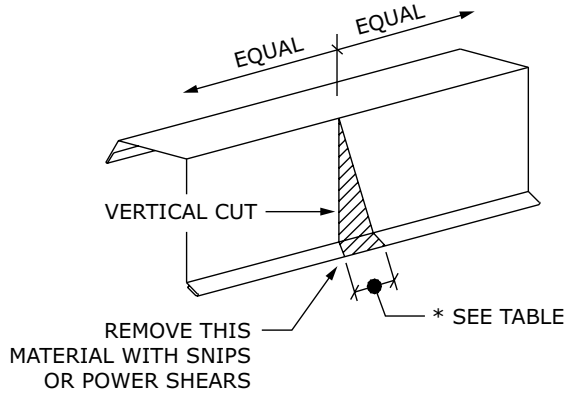

STEP 2

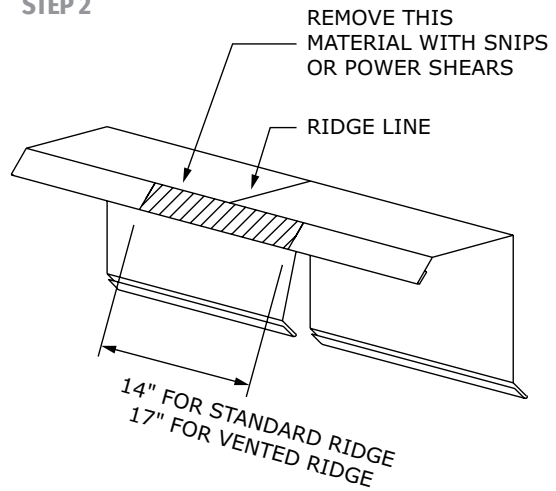

Roof Pitch	Dimension*
3:12	1 ¹ / ₁₆ "
3.5:12	1 ¹ / ₄ "
4:12	1 ¹ / ₈ "
5:12	1 ³ / ₈ "
6:12	2 ¹ / ₁₆ "
12:12	4 ⁷ / ₁₆ "

* Dimensions only apply to G4 Gable Flashing

STEP 3

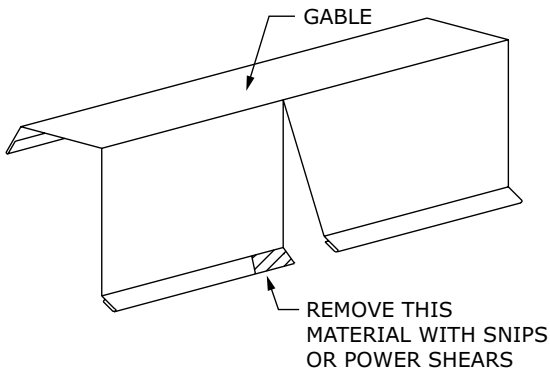

STEP 4

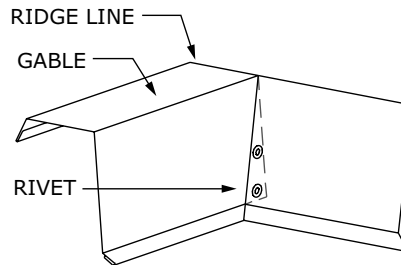

Metal Roofing Panels

Installation Guide for Delta Rib™, Delta Rib™ III, Nor-Clad®, Strata Rib® & 2½" Corrugated



Peak Flashing

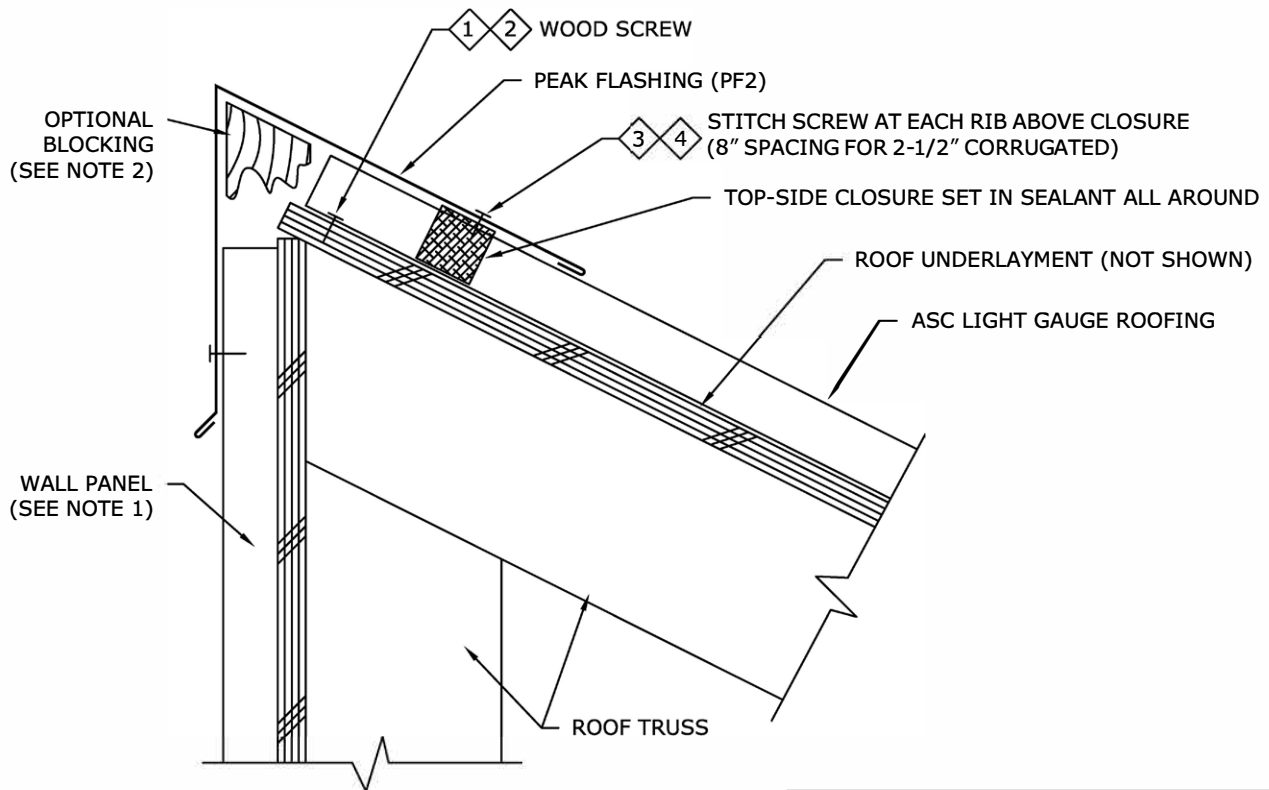
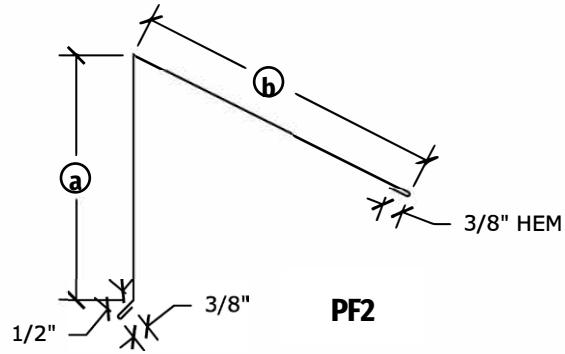

PF2 Roof Pitch	Dimension (a)	Dimension (b)
3:12-5:12	5-3/8"	5-1/4"
6:12-8:12	6"	5-3/4"
9:12-10:12	6-1/2"	6-1/4"
11:12-12:12	7-1/8"	6-5/8"

Procedures

- Fasten roofing panel to substrate at peak.
- Caulk the bottom and sides of top-side closure and place near peak. Locate closures where they will be hidden underneath peak flashing.
- Apply caulk along top of closure, and fasten peak flashing using stitch screws at every panel rib location.
- Caulk, lap, and rivet sequential flashings (see pg. 45).
- Close the ends of the peak at gable ends by slitting and folding material at each end, caulking joints, and fastening with rivets.

Notes:

1. Peak flashing dimensions noted on this installation detail based on nominal 1" thick wall facing. Different wall panel thicknesses may require some adjustments to peak flashing dimensions and/or positioning of roof assembly components.
2. Additional blocking may be required at peak to support peak flashing.

Vented Peak Flashing

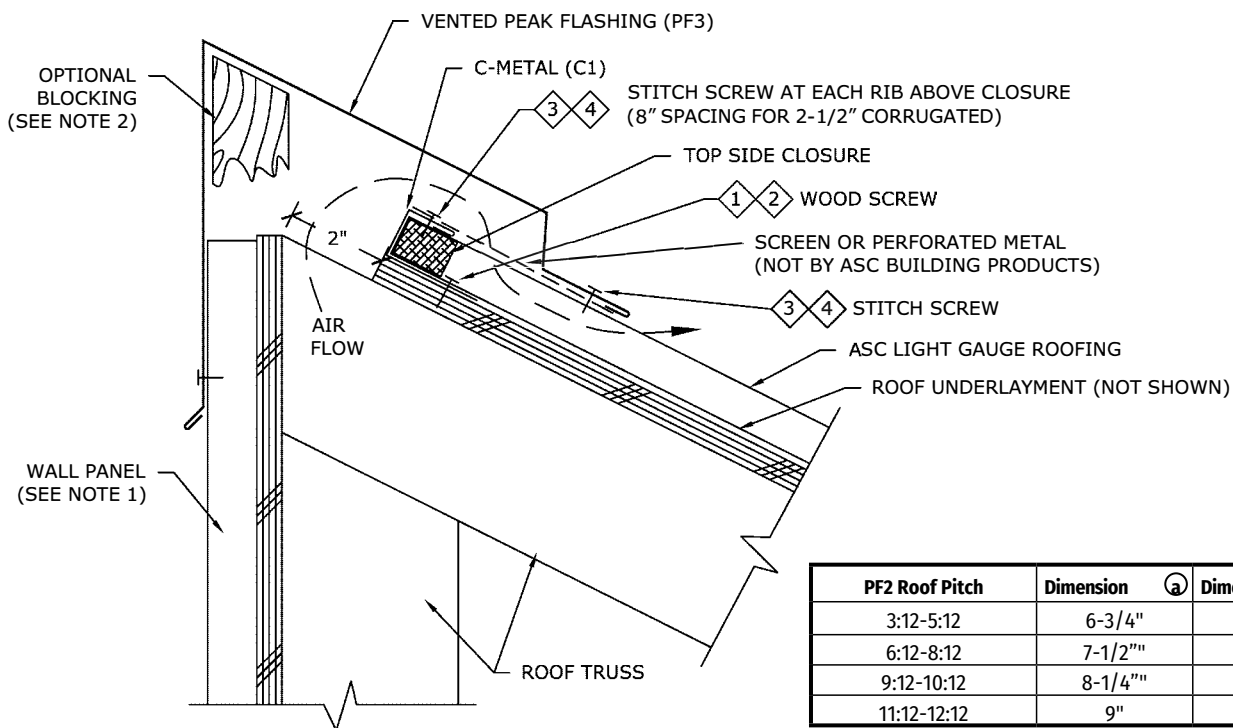
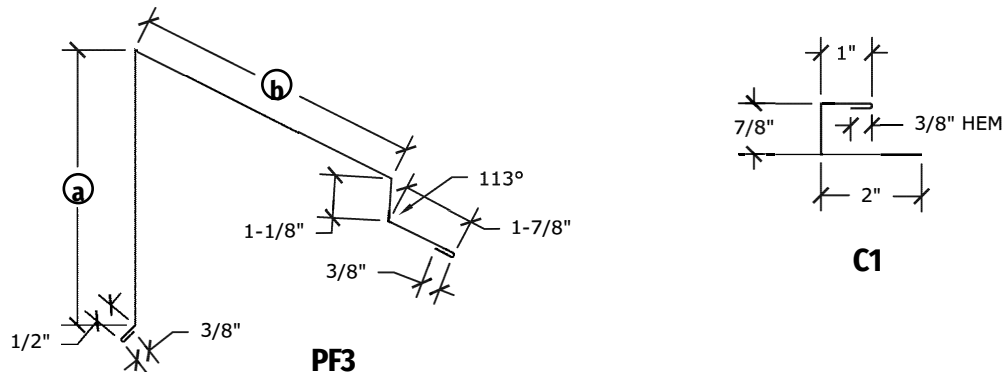

PF2 Roof Pitch	Dimension $\text{\textcircled{a}}$	Dimension $\text{\textcircled{b}}$
3:12-5:12	6-3/4"	7"
6:12-8:12	7-1/2"	7-7/8"
9:12-10:12	8-1/4"	8-5/8"
11:12-12:12	9"	9-1/4"

Procedures

- Substrate should be held back 2" from the peak.
- Locate the panels at the top end of the substrate. Install C-metal onto end of panel and fasten panel and C-metal into place. Check panel positioning at eave before fastening.
- Insert top-side closure onto panel, at C-metal location.
- Attach the screen at each panel rib, sandwiching the topside closure in place. Ensure screen is pulled tight to avoid sagging.
- Fasten the vented peak flashing using stitch screws at panel rib locations.
- Caulk, lap and rivet sequential flashings (see page 45).
- Close the ends of the peak at gable ends by cutting and folding material at each end. Fasten with rivets and caulking joints. (see page 12).

Notes:

1. Peak flashing dimensions noted on this installation detail are based on nominal 1" thick wall facing. Different wall panel thicknesses may require some adjustments to peak flashing dimensions and/or positioning of roof assembly components.
2. Additional blocking may be required at peak to support peak flashing.

Metal Roofing Panels

Installation Guide for Delta Rib™, Delta Rib™ III, Nor-Clad®, Strata Rib® & 2½" Corrugated



Sidewall Flashing

This flashing must be installed prior to wall panels.

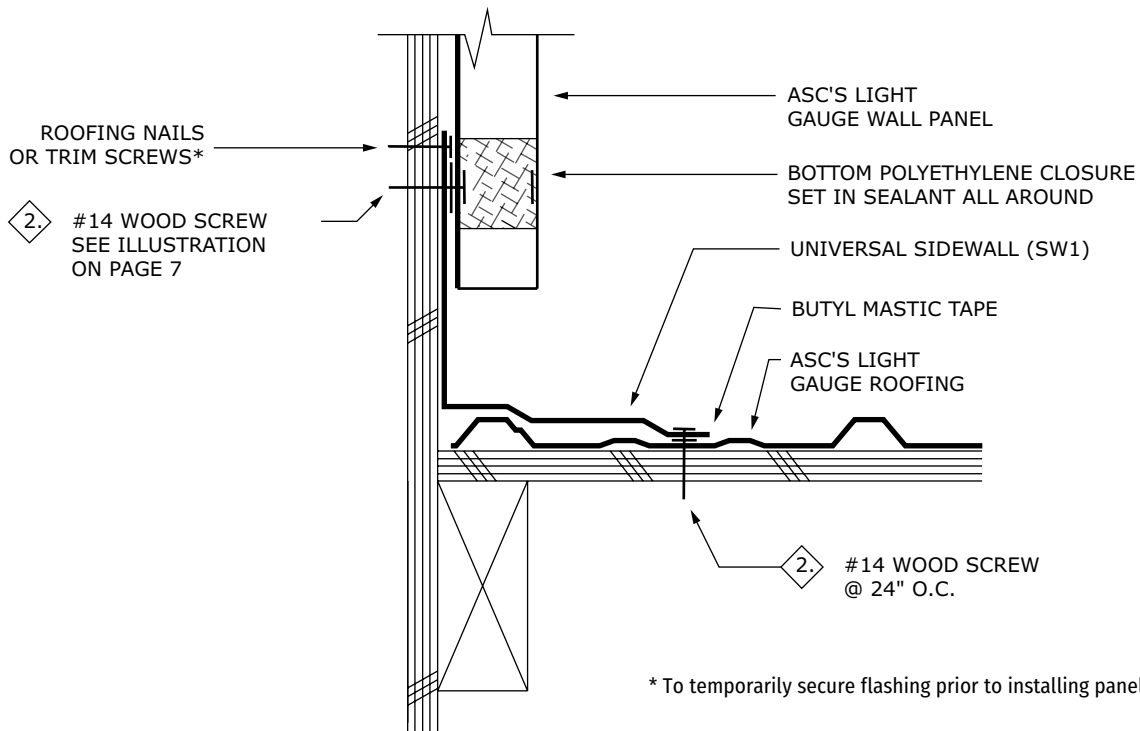
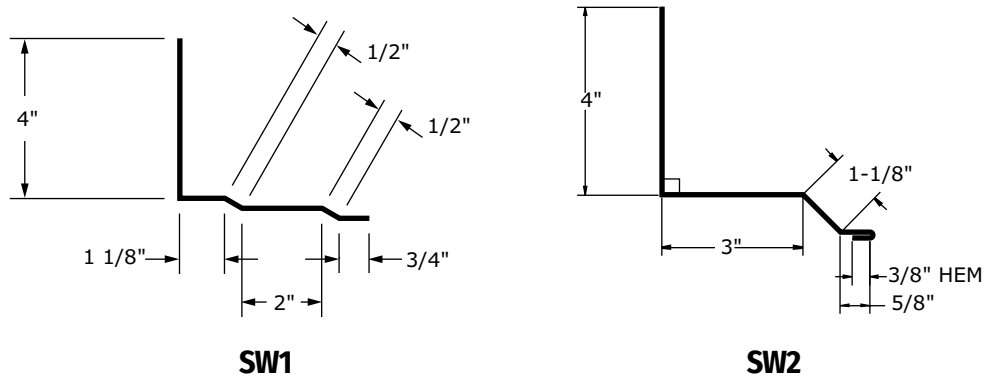

Procedures

- The roof should be installed prior to the siding.
- Place butyl mastic tape along the top of the panel as shown.
- Install the side wall flashing by placing it firmly on the roofing panel and fastening with the fastener indicated.
- Caulk and lap the flashing a minimum of 3". (see page 45)

Endwall Flashing

This flashing must be installed prior to wall panels.

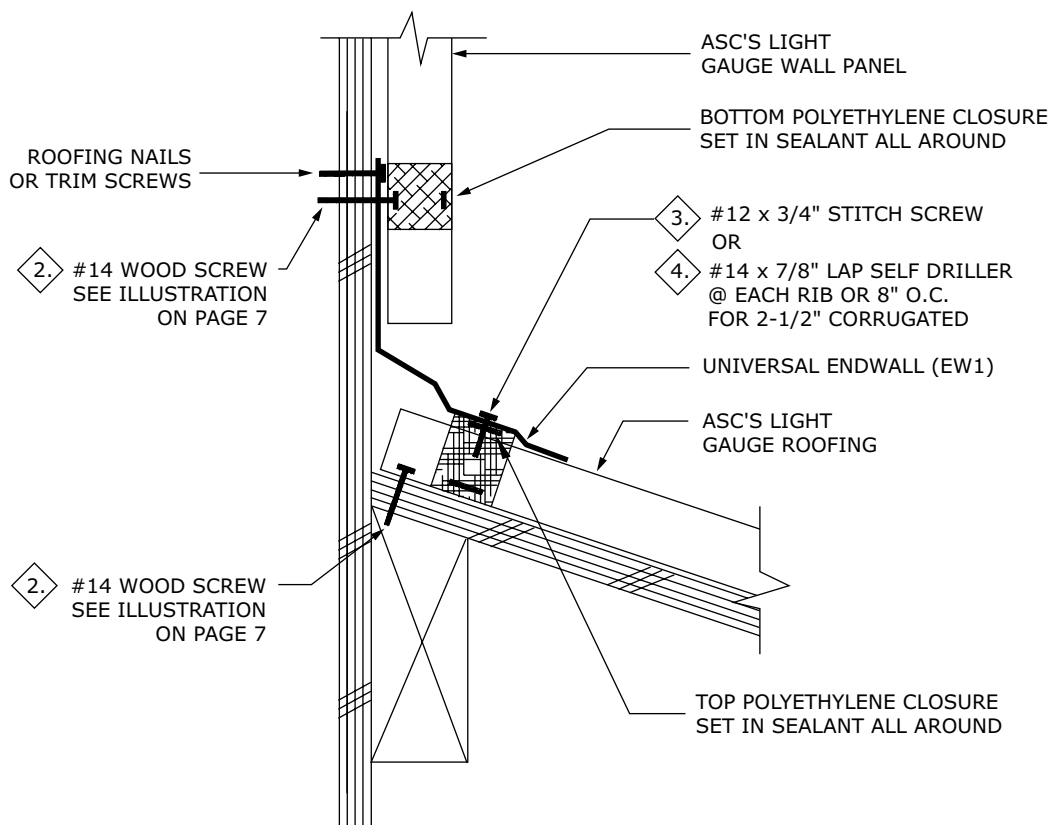
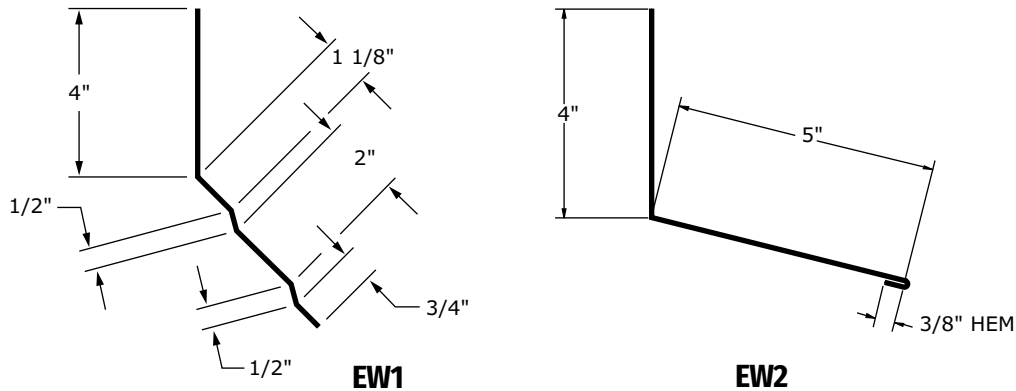

Procedures

- Install sealant on the bottom and top of the polyethylene closure. Set the closure as shown above.
- Fasten the end wall flashing to the wall with roofing nails or trim screws to temporarily secure flashing prior to installing panels.
- Caulk and lap the flashing a minimum of 3". (see page 45)

Metal Roofing Panels

Installation Guide for Delta Rib™, Delta Rib™ III, Nor-Clad®, Strata Rib® & 2½" Corrugated



Vented End Wall Flashing

This flashing must be installed prior to wall panels.

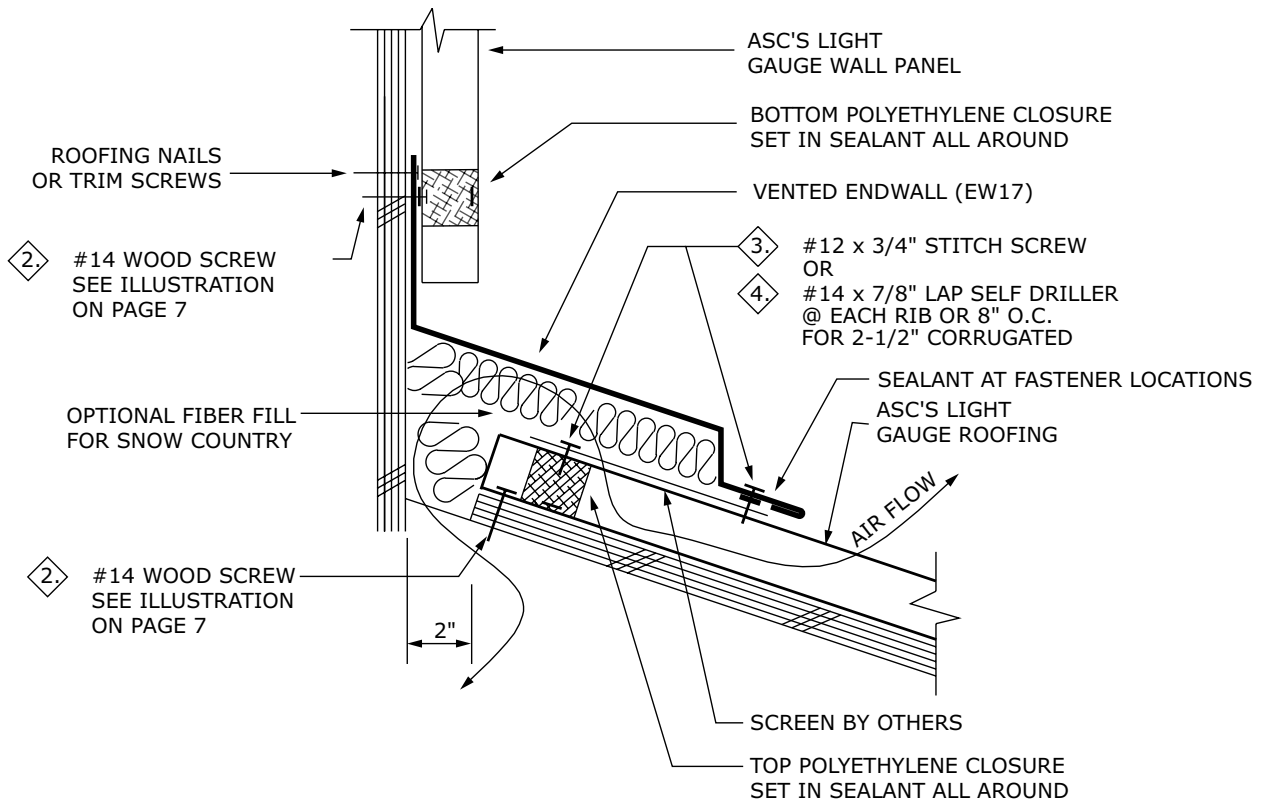
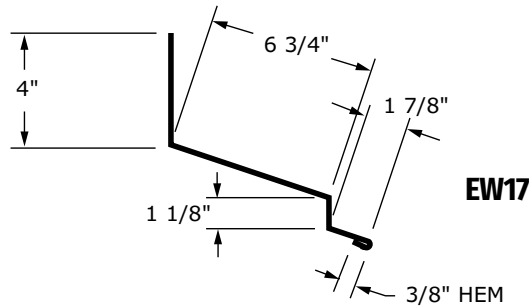

Procedures

- Substrate should be held back 2" from the wall.
- Install sealant on the bottom and top of the polyethylene closure. Set the closure as shown above.
- Fasten the end wall flashing to the wall with roofing nails at 24" or trim screws to temporarily secure flashing prior to installing panels.
- Fasten the flashing to each rib with #12 x ¾" stitch screws. Place a short bead of sealant on top of each rib as shown. (8" spacing for 2-1/2" Corrugated)
- Caulk and lap the flashing a minimum of 3". (see page 45)
- For SFS VistaVent® or ProfileVent® alternate venting, use (EW1) for vented endwall flashing detail.

Slope Transition - High Slope to Low Slope

This flashing must be installed prior to uphill panels.

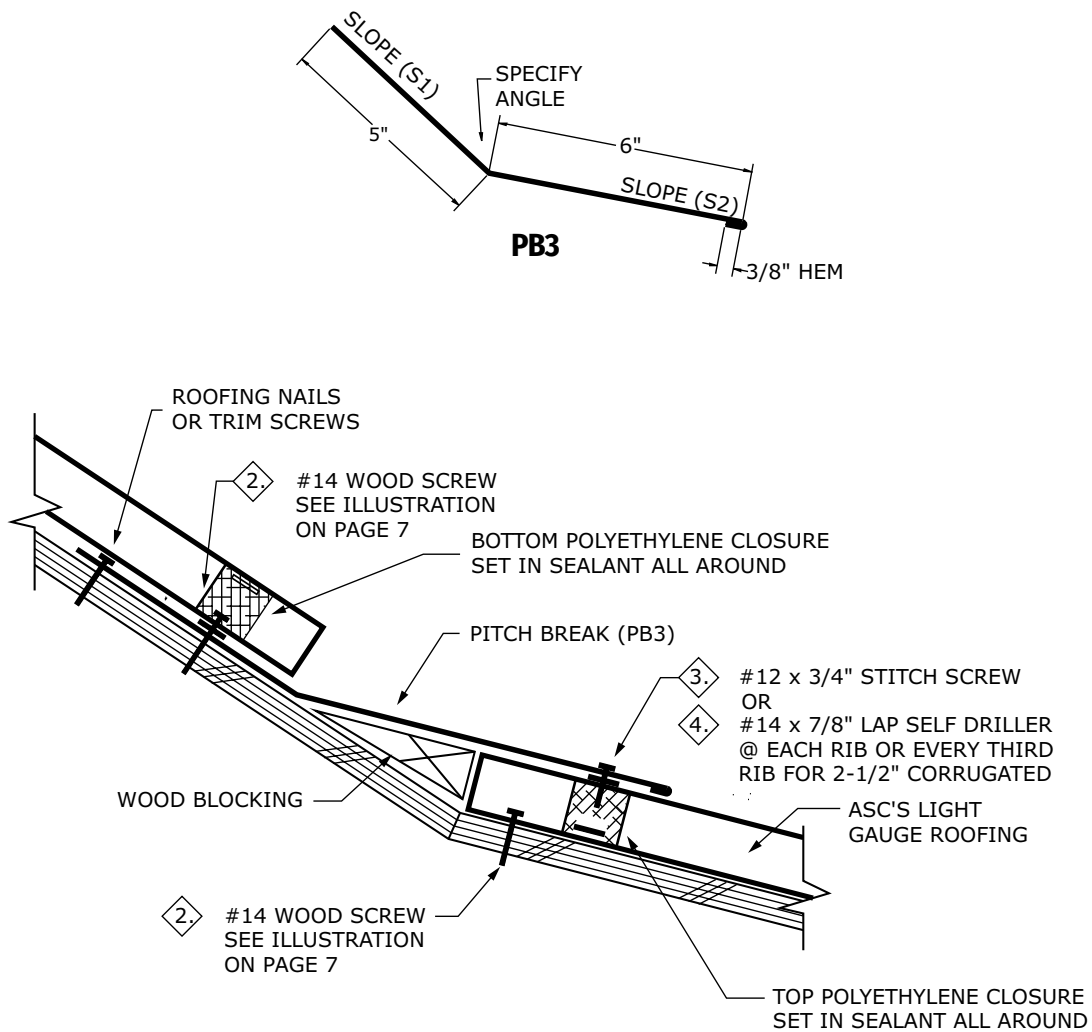

Procedures

- Install sealant on the bottom and top of the polyethylene closure. Set the closure as shown above.
- Fasten the transition flashing to the substrate with roofing nails or trim screws to temporarily secure flashing prior to installing panels.
- Caulk and lap the flashing a minimum of 3". (see page 45)
- Attach the uphill panels as shown.
- Install wood blocking as needed for support.
- Place a small length of sealant on the top of each rib as shown.

Metal Roofing Panels

Installation Guide for Delta Rib™, Delta Rib™ III, Nor-Clad®, Strata Rib® & 2½" Corrugated



Slope Transition - Low Slope to High Slope

This flashing must be installed prior to uphill panels.

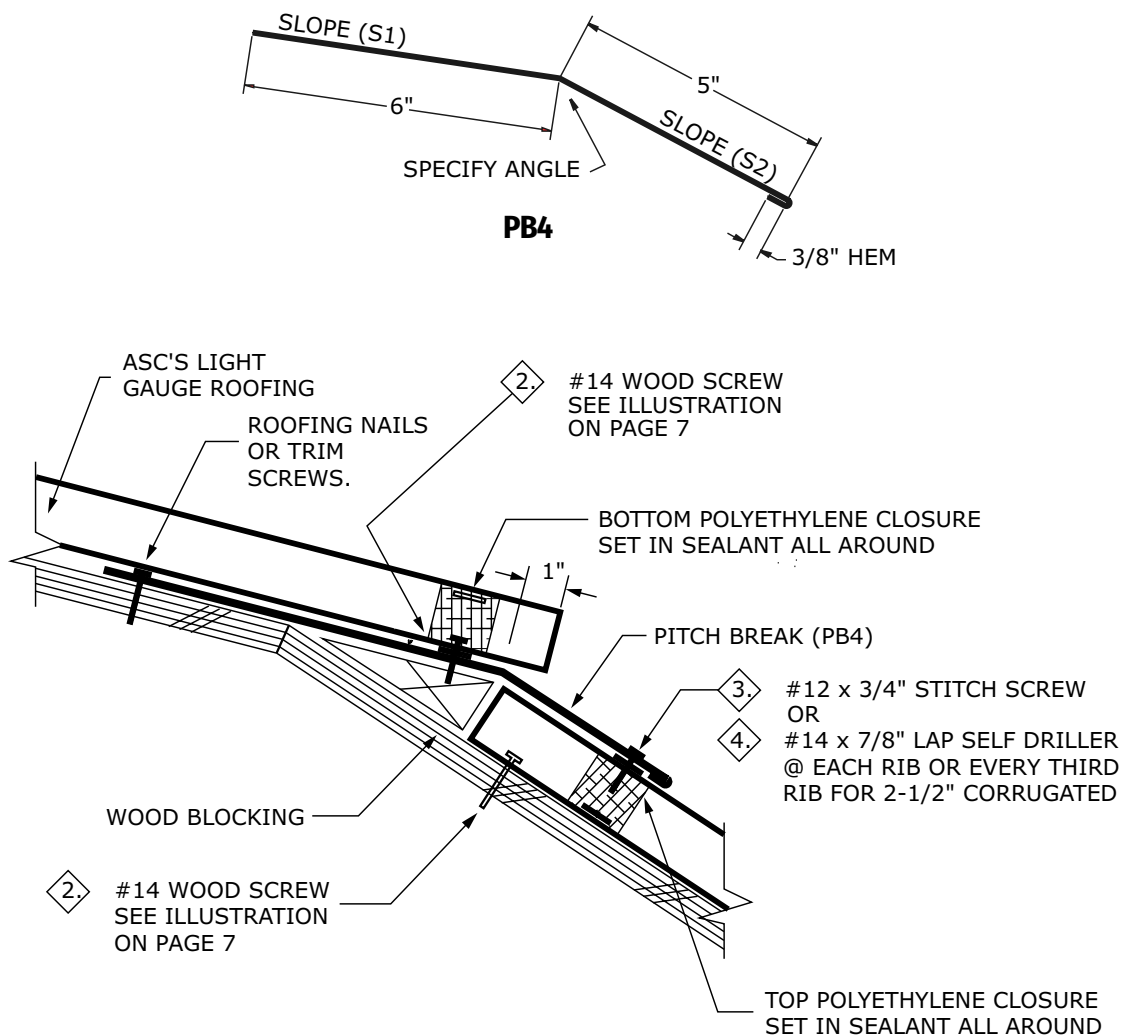

Procedures

- Install sealant on the bottom and top of the polyethylene closure. Set the closure as shown above.
- Fasten the transition flashing to the substrate with roofing nails or trim screws prior to installing the uphill panels.
- Caulk and lap the flashing a minimum of 3". (see page 45)
- Attach the uphill panels with a 1" overhang.
- Install wood blocking as needed for support.
- Place a small length of sealant on the top of each rib as shown.

Chalet Gable Flashing

This flashing must be installed prior to panels.

* THIS DETAIL IS ALSO KNOWN AS
A "PROW" OR "DUTCH" GABLE ROOF.

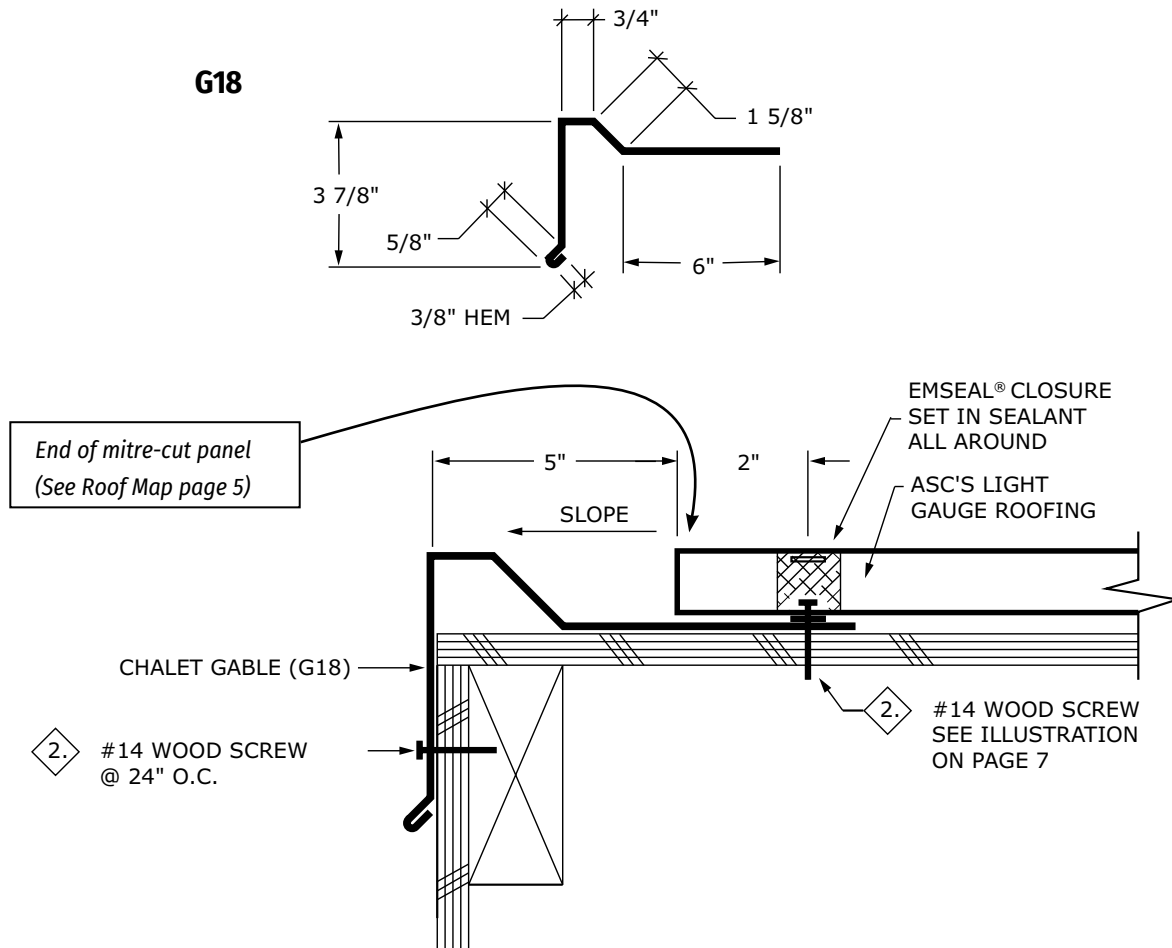

Procedures

- Attach the chalet flashing using color matched wood screws spaced at 24" o.c.
- Polyethylene closures cannot be installed diagonally across angle cut panel ends. Use Emseal® closures parallel to cut edge to seal voids under panel ends.
- Field cut the panels holding 5" back from the face of the flashing as shown.
- Attach the panels to the roof along the bottom edge using #14 wood screws evenly spaced at 4" o.c. and approximately 2" from panel ends at closure location.
- Chalet gable to be used with standard eave "E1". (see page 15)

Adjustable Gable Flashing

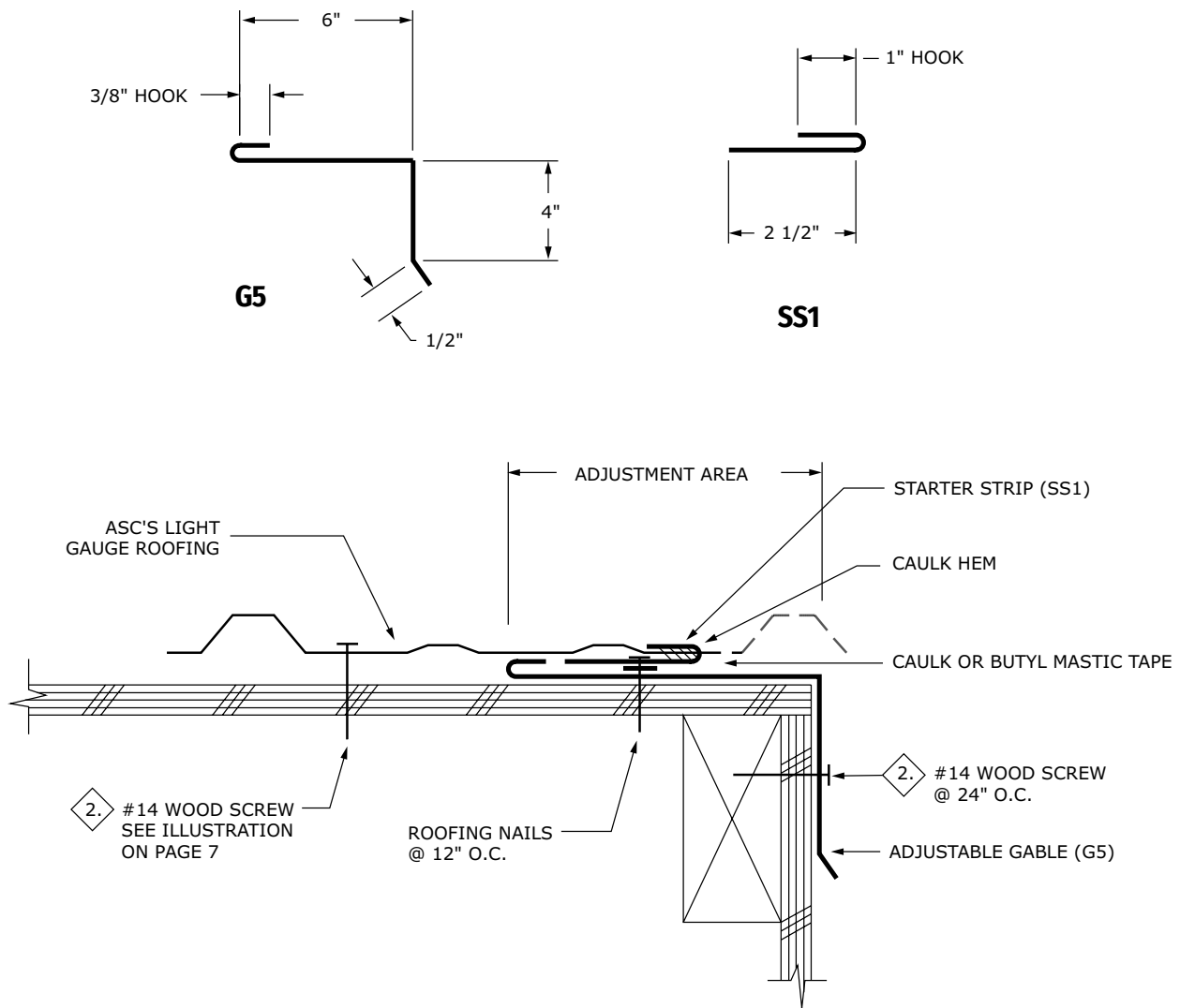

Procedures

- In many instances, the roof sheet will have to be field modified (major rib removed along the gable). See roof map on page 5 and locate "adjustable gable". If gable trims are used in this location, and as the roof drains from the ridge, water will flow inside the gable trims shown on page 18. The adjustable gable trim pieces shown above can assist in a proper roof installation.
- When a major rib on a metal roofing panel occurs over the roof area within 3" of the edge of the gable, cut the panel and remove the major rib from the end of the sheet from the low eave to allow for the placement of the starter strip.
- Install the gable trim, extending the horizontal leg 6" uphill and underneath the eave on the portion of the roof sheet at the gable/eave intersection.
- Locate the placement of the starter strip to insure that the cut edge of the roof sheet can be inserted into the 1" leg of the starter strip.
- Field caulk inside the open hem and the under side of the starter strip per the detail on this page and install parallel to gable.

Note: Locate starter strip to allow proper installation of adjustable gable trim as shown.

Vent Flashing

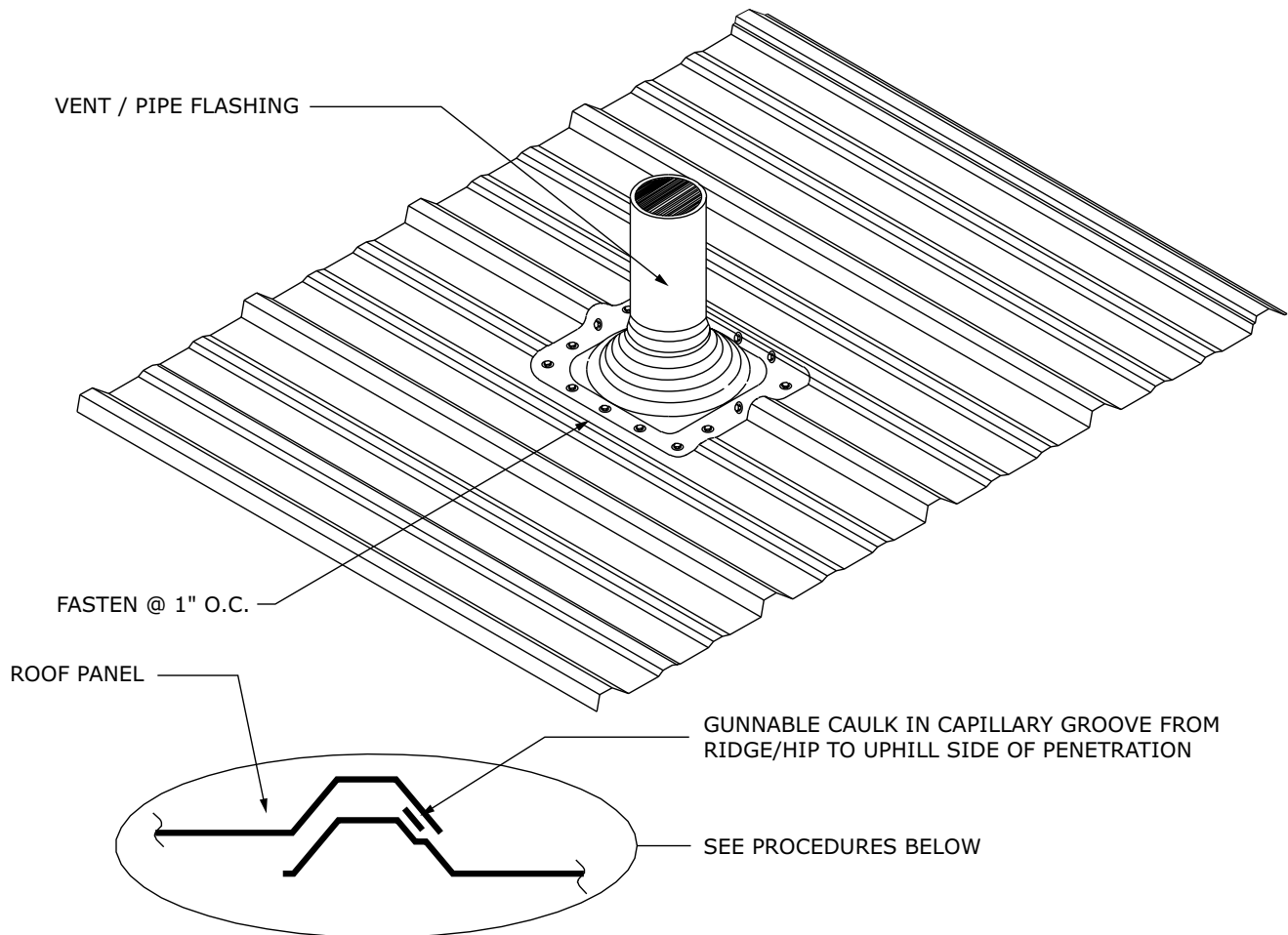

ILLUSTRATION #5

Procedures

- Trim the opening in the flashing to 20% smaller than the pipe diameter.
- Slide the flashing down over the pipe.
- Seal between the vent flashing and the roofing with gunnable caulk and set the flashing.
- Form the flashing to fit the profile of the roof.
- Fasten the flashing with fasteners at 1" o.c. Refer to the fastener selection guide on page 7.
- Penetrations occurring over spaced supports may require additional support framing.
- A stainless steel draw band should be installed at the top of the vent/pipe flashing.
- A minimum drainage area of 2" should be maintained between both sides of the flexible vent/pipe flashing base and the roof panels' major ribs.
- When a penetration occurs through a panel sidelap, gunnable caulk needs to be installed in the capillary groove from the penetration to the ridge. This will prevent water from running downhill in the capillary groove and into the roof opening. *Refer to illustration #5, above.*

Note: For the best drainage when a square-based pipe flashing is used, one corner of the flexible pipe flashing should be oriented to the high-side of the roof.

Vent/Pipe Flashing Installation Procedure

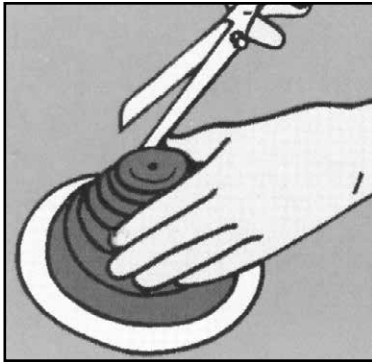

STEP 1: Cut

Cut to pipe diameter marked on Flashers (this is approximately 20% smaller than the diameter of the pipe).

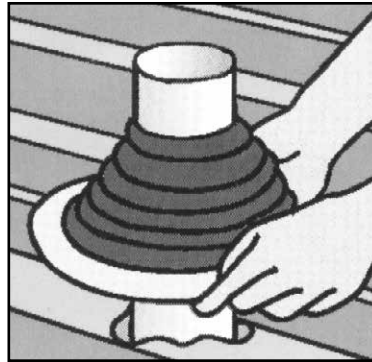

STEP 2: Slide

Slide the Flashers down the pipe, using water to lubricate if necessary.

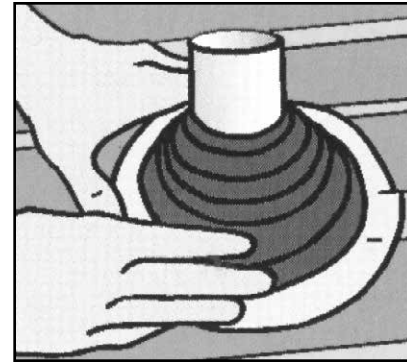

STEP 3: Form

Form and bend the aluminum base of the Flashers to fit the surface of the roof.

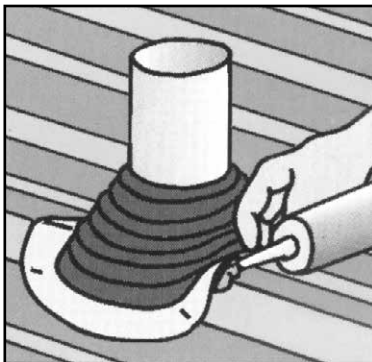

STEP 4: Seal

Seal the Flashers by applying urethane/silicone sealant between the Flasher and the roof. Use a large slot screwdriver to press the base down tightly.

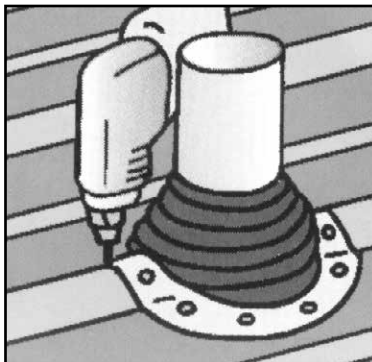

STEP 5: Fasten

Fasten the Flashers with weather-resistant fasteners to complete the seal.

Note: For the best drainage when a square-based pipe flashing is used, one corner of the flexible pipe flashing should be oriented to the high-side of the roof.

Skylight Flashing

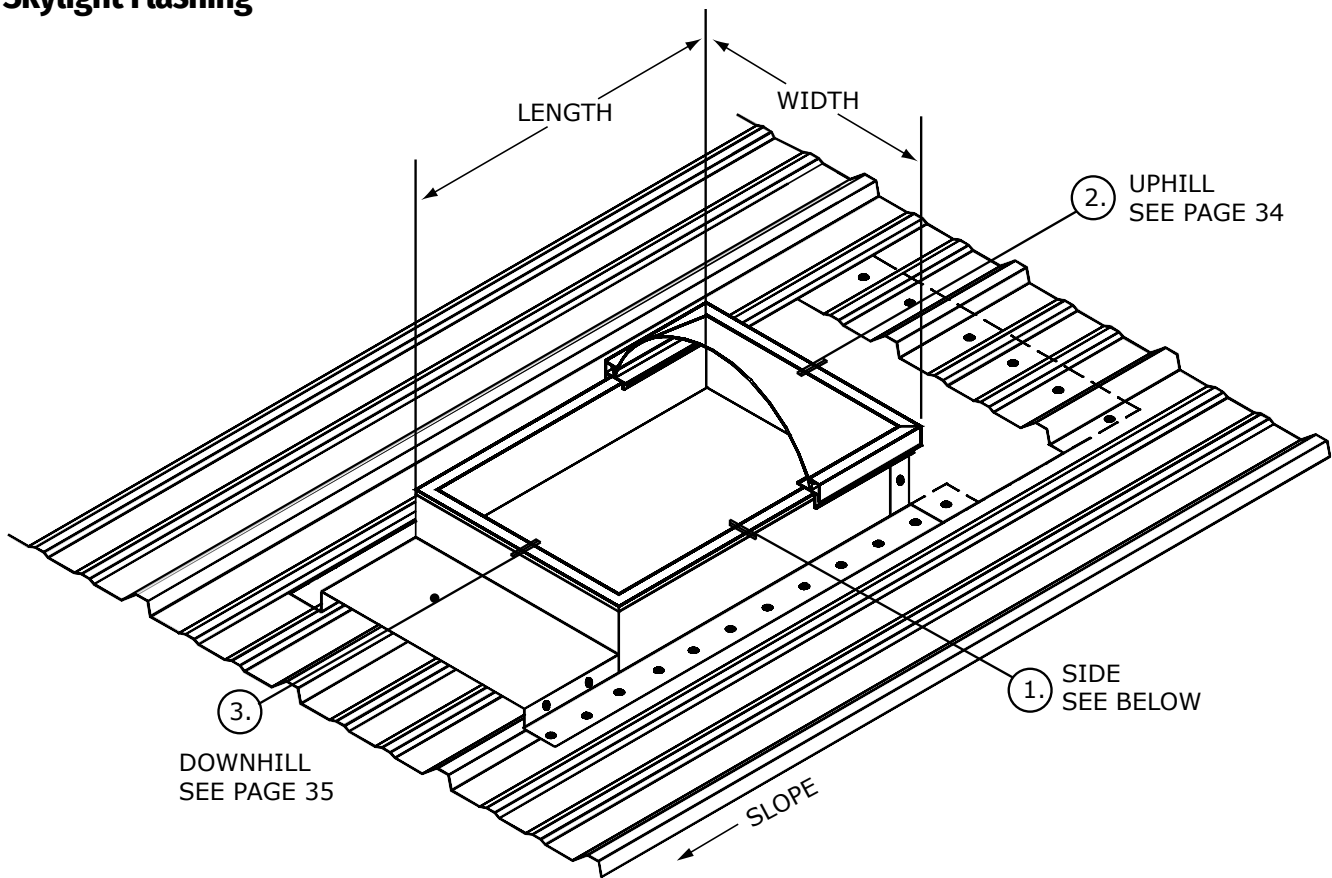

- Wherever possible, position the skylight curb so the ribs of the roof panels do not interfere with the flashing.
- Cut the metal roof panels as close to the left, right and downhill sides of the curb as possible. Cut the uphill side 6" up from the curb as indicated above.
- Penetrations occurring over spaced supports require additional support framing.

Note: Do not fasten the panels within 24" uphill from the skylight until the penetration flashing is installed.

1 - Skylight Flashing (Side)

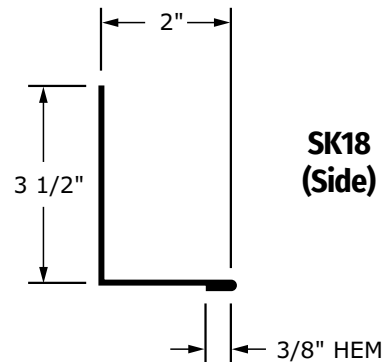
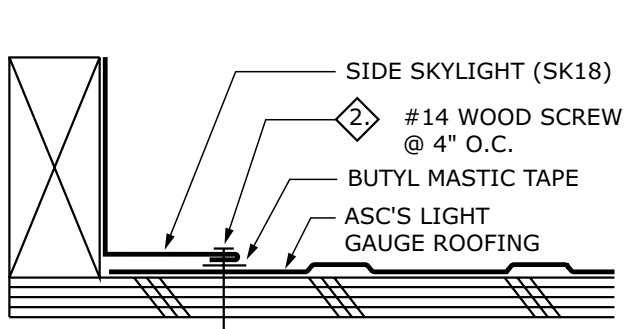

Metal Roofing Panels

Installation Guide for Delta Rib™, Delta Rib™ III, Nor-Clad®, Strata Rib® & 2½" Corrugated



2 - Skylight Flashing (Uphill Side)

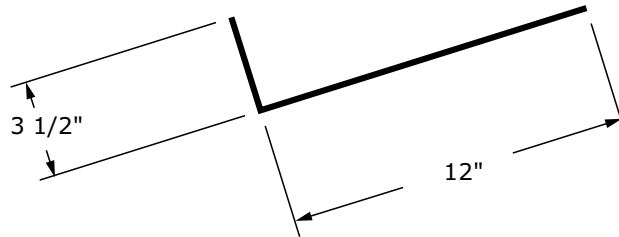

**SK16
(Uphill)**

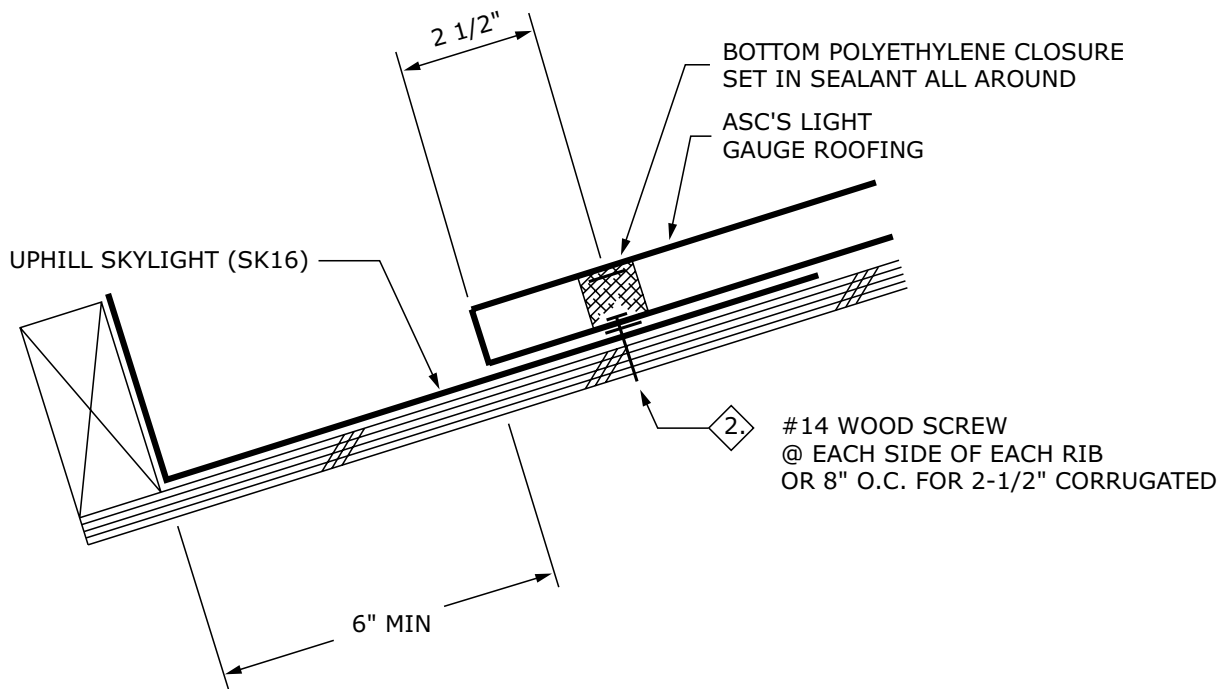

3 - Skylight Flashing (Downhill Side)

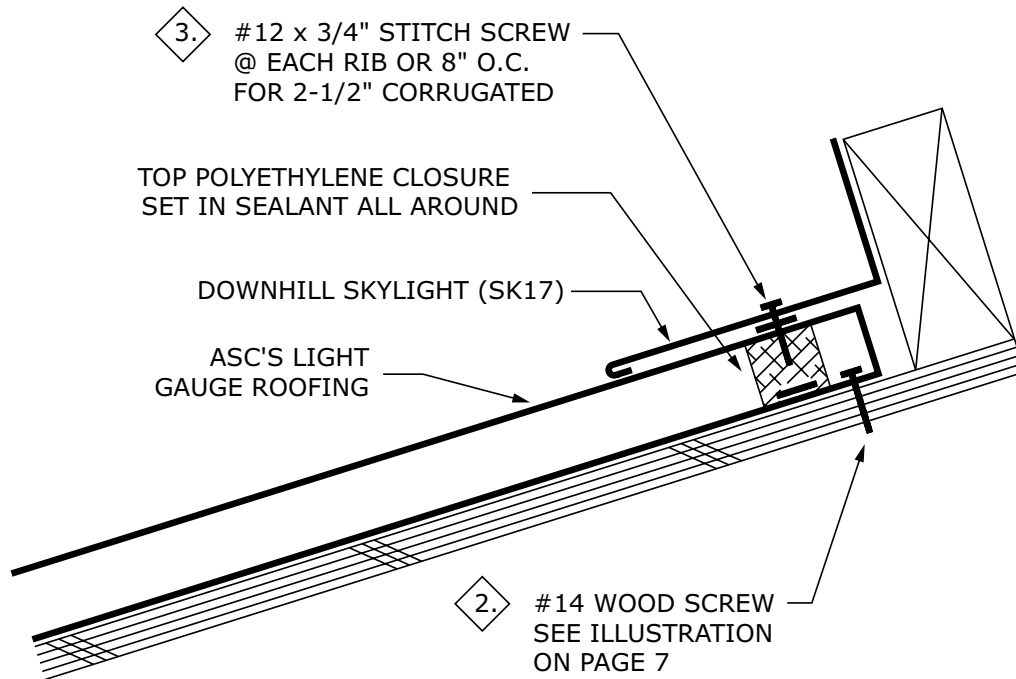
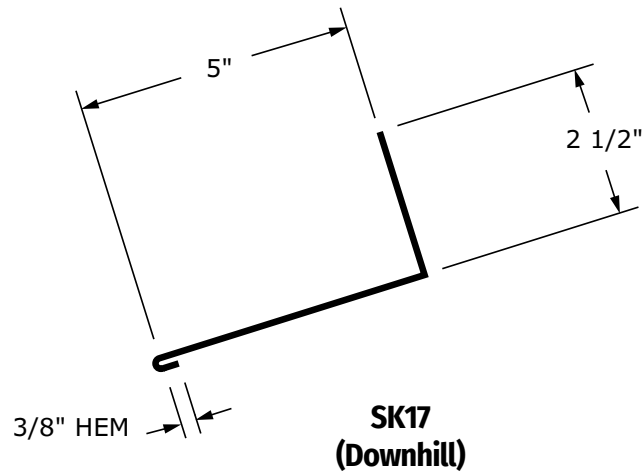

Procedure for the Installation of Skylight Flashings

**REFER TO
INSTALLATION VIDEO
FOR CLARIFICATION**

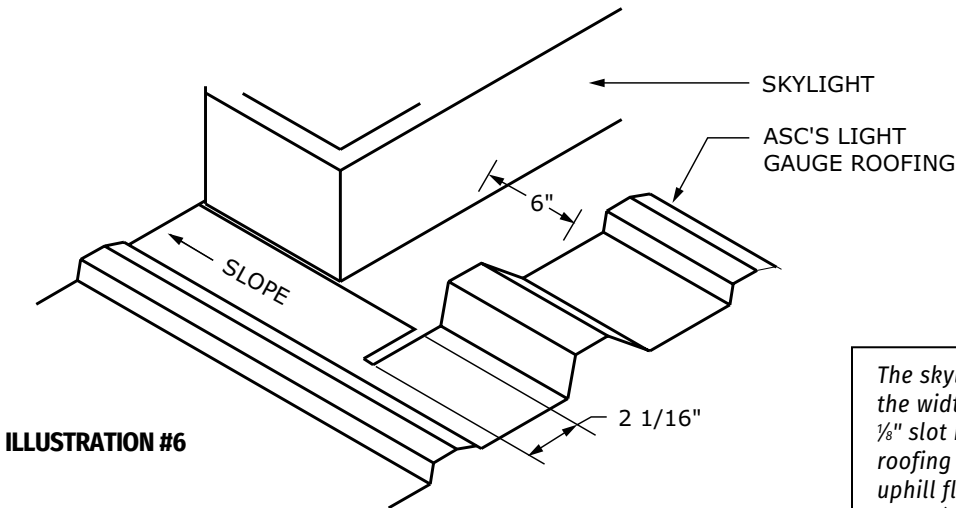
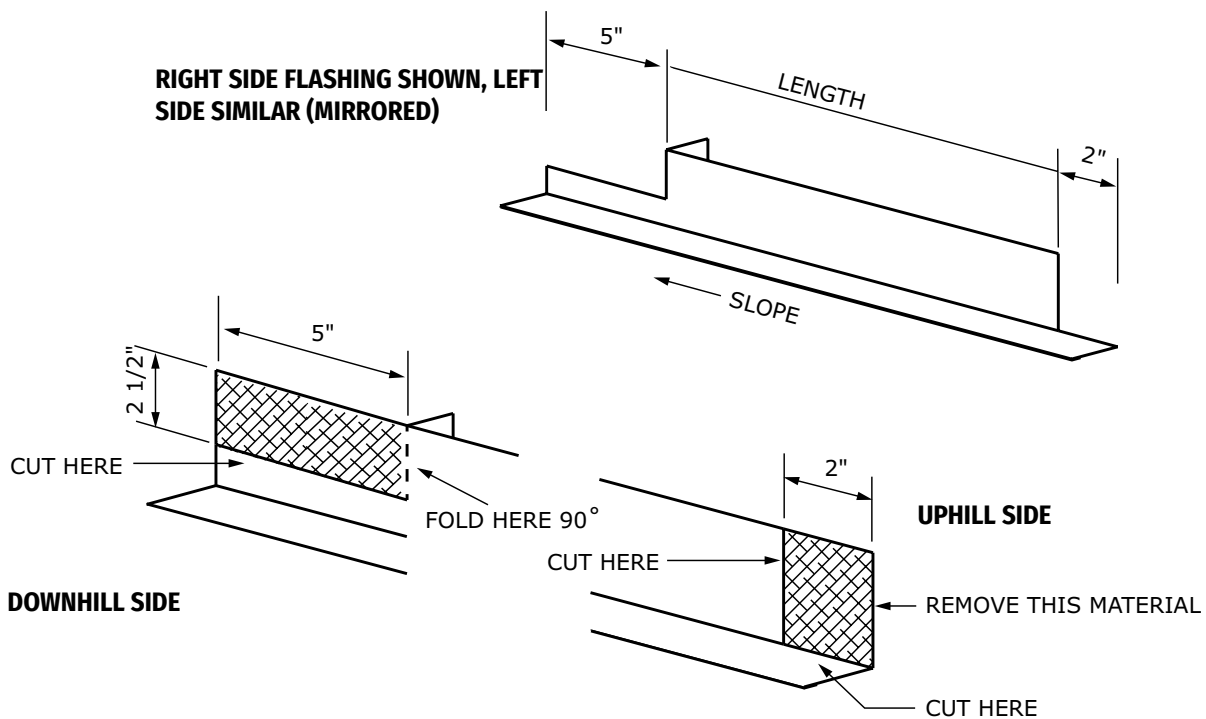

ILLUSTRATION #6

The skylight flashing will be 4" wider than the width of the curb (2" on each side). Cut a 1/8" slot in the two uphill corners of the metal roofing panel slightly wider than 2", so the uphill flashing can slide through the two slots. (See illustration #6).

Adjustments to the horizontal leg dimension and length of slit may have to be modified depending on the location of the panels' major rib.

Skylight Flashing Preparation



Skylight Flashing Preparation (continued)

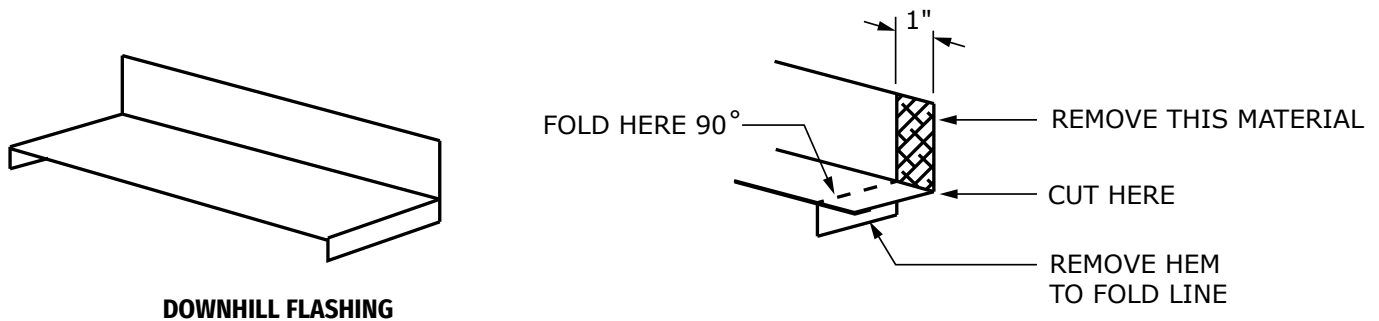
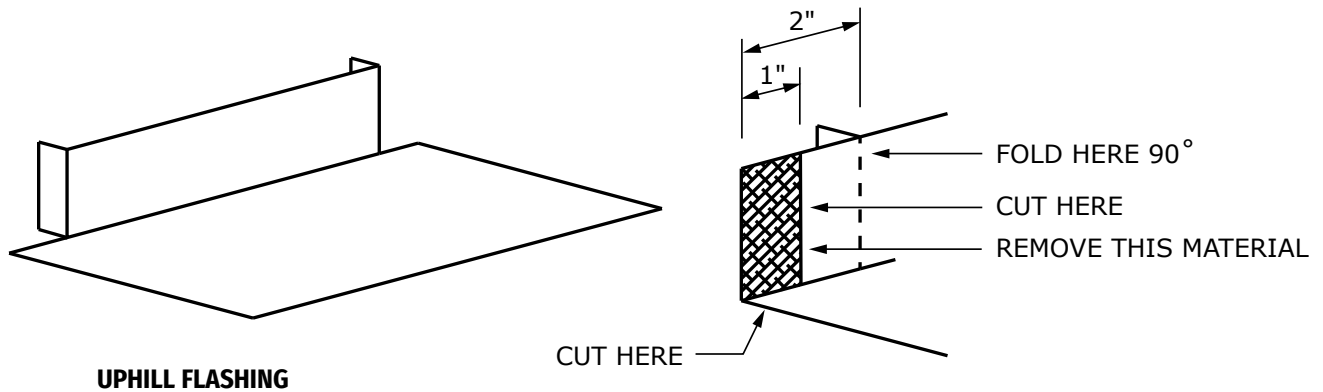

Procedures

- Trim both ends of the uphill and downhill sides of the skylight flashing as indicated.
- Slide the uphill flashing into the slots of the metal roofing and apply liberal amount of gunnable caulking.
- Assemble the skylight as indicated on *pages 34-37*.
- Trim and assemble chimney flashing similarly.

Metal Roofing Panels

Installation Guide for Delta Rib™, Delta Rib™ III, Nor-Clad®, Strata Rib® & 2½" Corrugated



Chimney Flashing

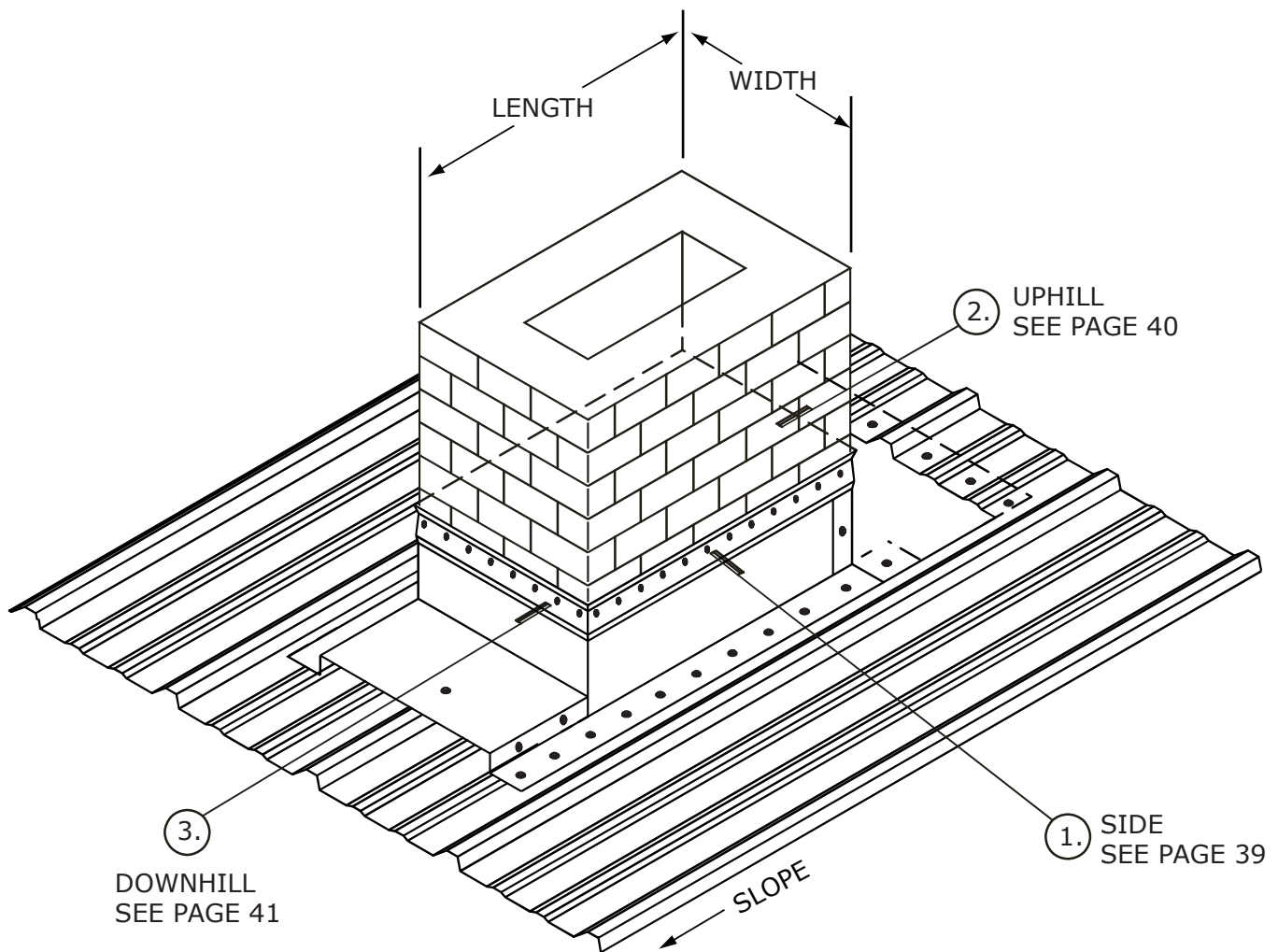

Note: Procedures for the installation of chimney flashings are similar to the skylights. (see pgs. 34-37). The reglet** shown may be deleted if the chimney is clad with siding. (Lap the siding over the flashing and caulk). Be sure to specify the slope and the orientation of the chimney dimensions when ordering this assembly.

** A reglet is a two-piece flashing found on the side of a wall, chimney or other similar roof penetration. (see flashing drawing page 40).

1 → Chimney Flashing (Side)

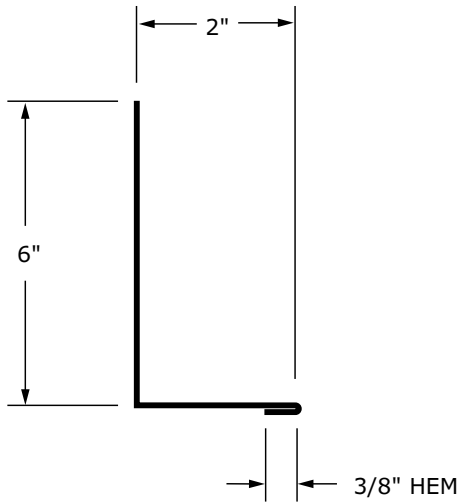

**CH18
(Side)**

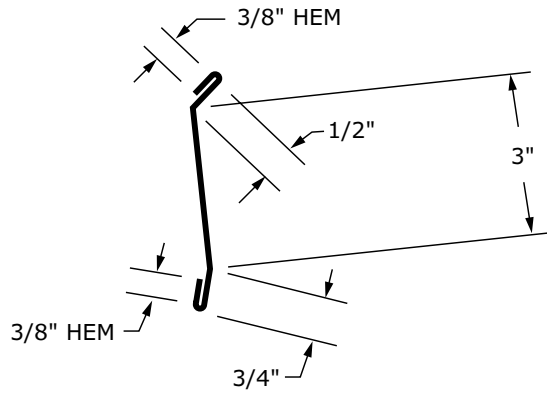

**RG16
(Reglet)**

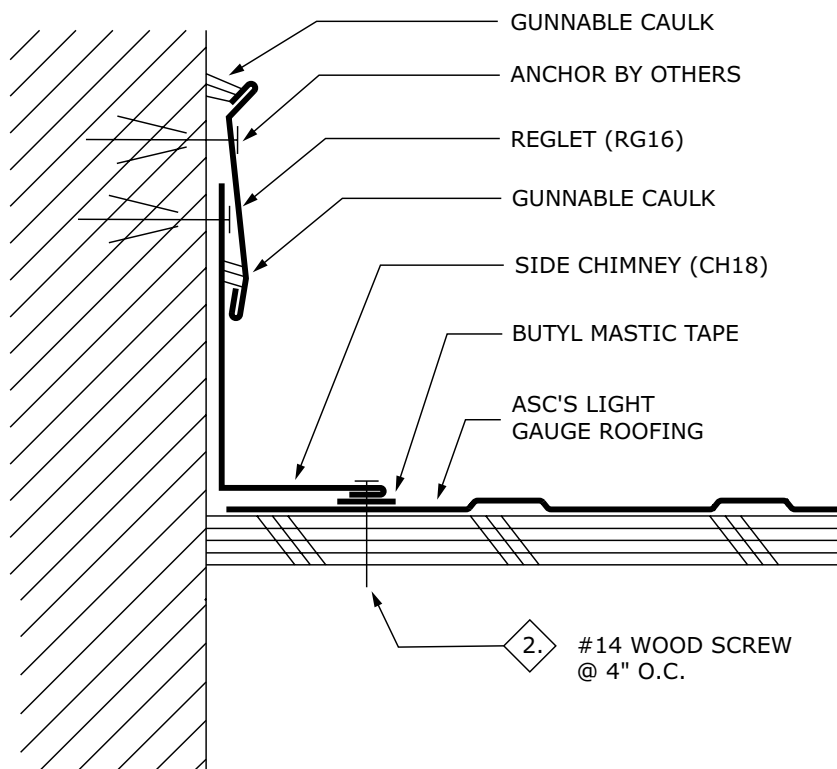

Metal Roofing Panels

Installation Guide for Delta Rib™, Delta Rib™ III, Nor-Clad®, Strata Rib® & 2½" Corrugated



2 Chimney Flashing (Uphill)

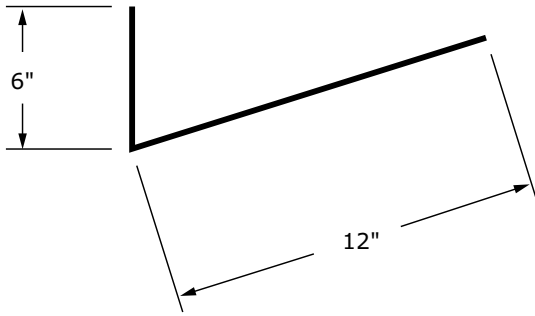

**CH16
(Side)**

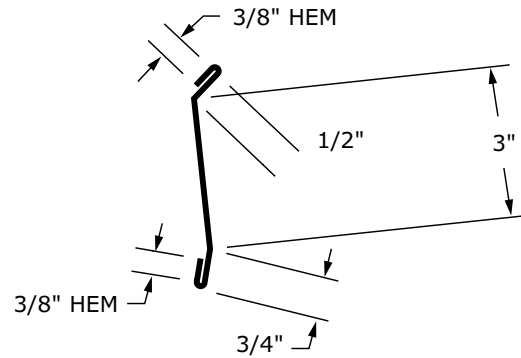

**RG16
(Reglet)**

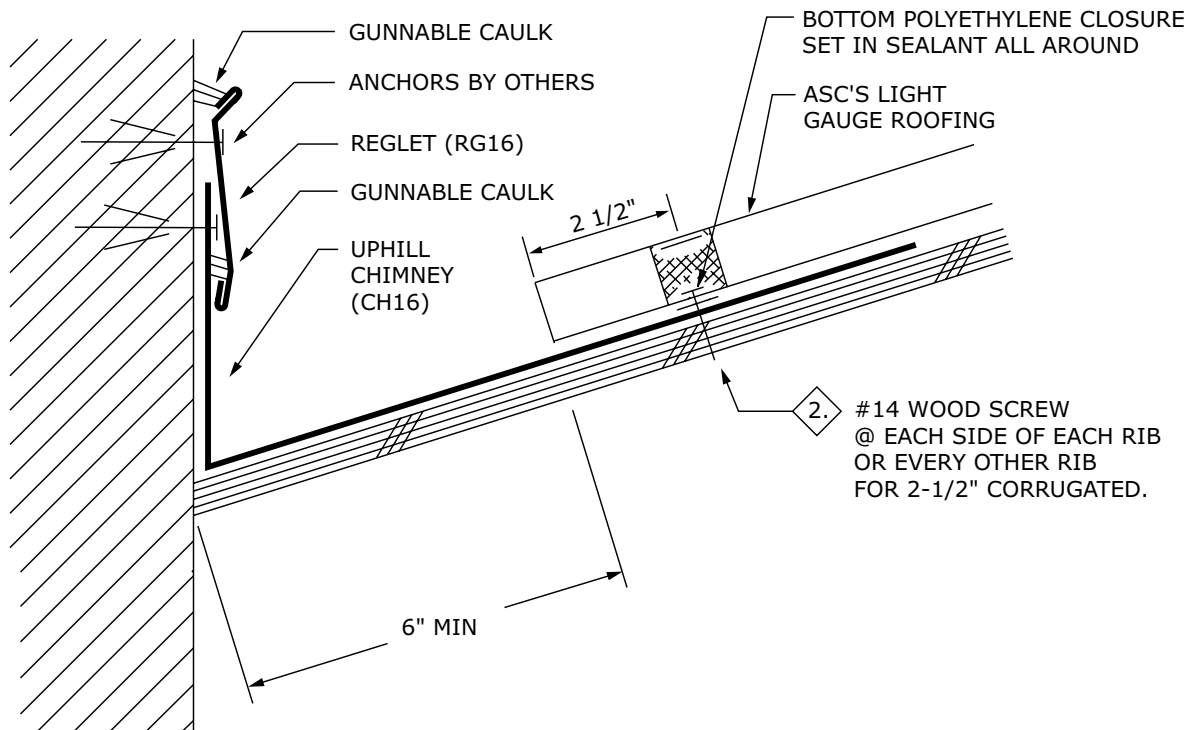

3 Chimney Flashing (Downhill)

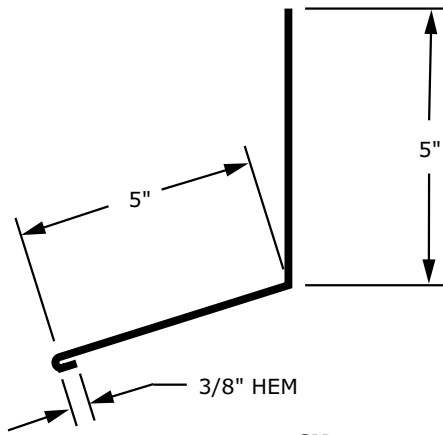

**CH17
(Downhill)**

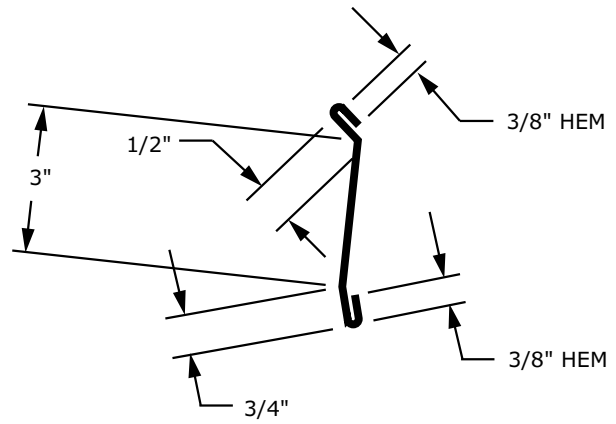

**RG16
(Reglet)**

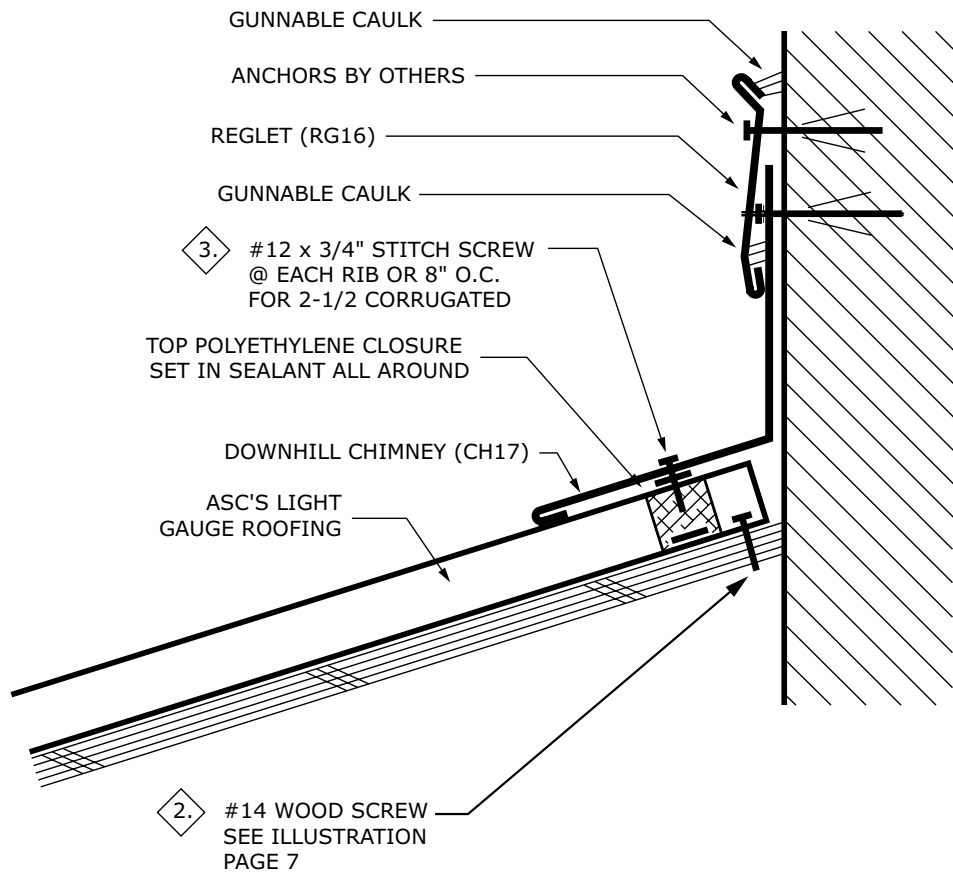

Metal Roofing Panels

Installation Guide for Delta Rib™, Delta Rib™ III, Nor-Clad®, Strata Rib® & 2½" Corrugated



Valley Top End

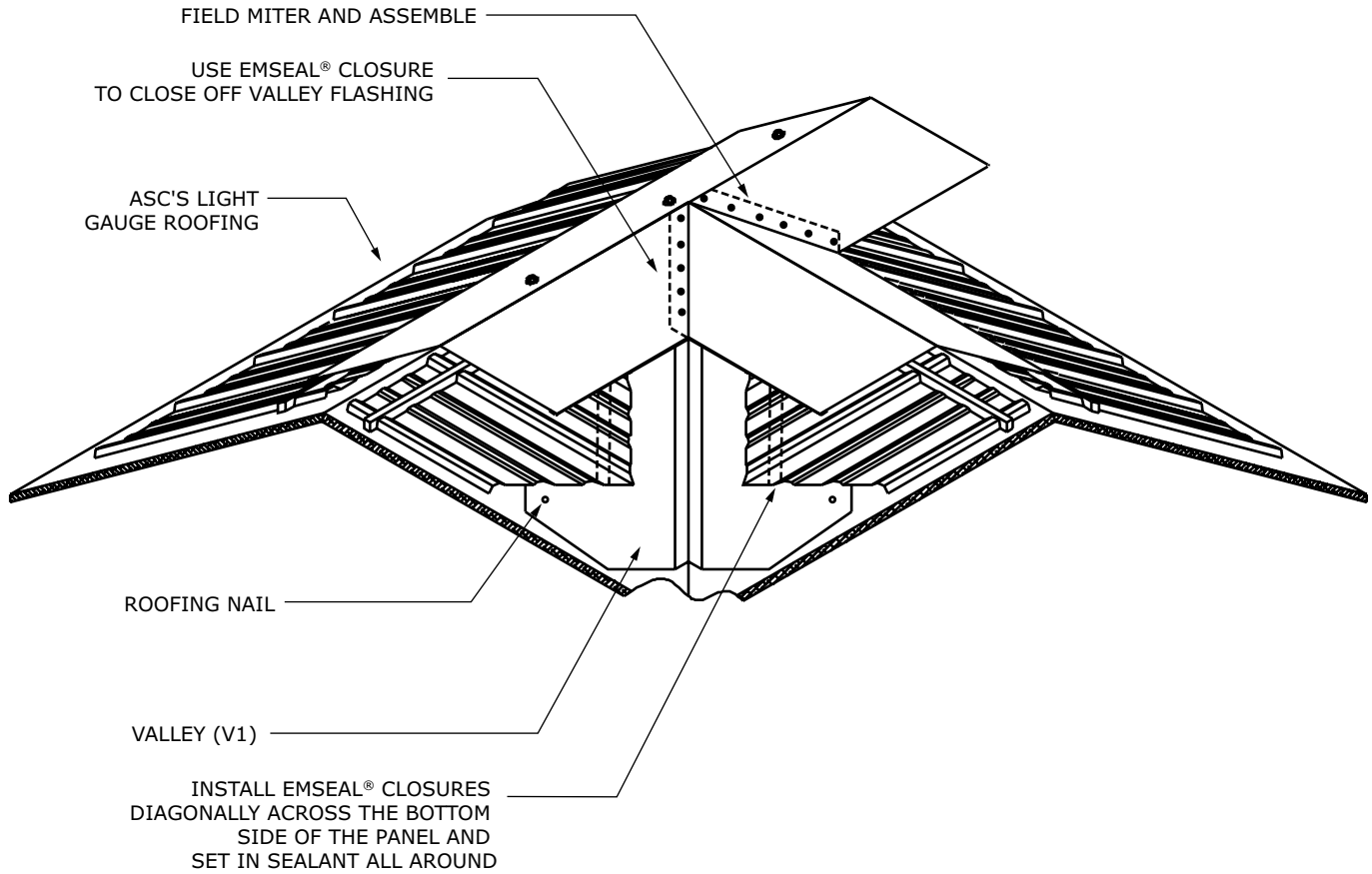

Note: Refer to Ridge and Valley installation details within this guide for further clarification on those areas.

Valley Dormer

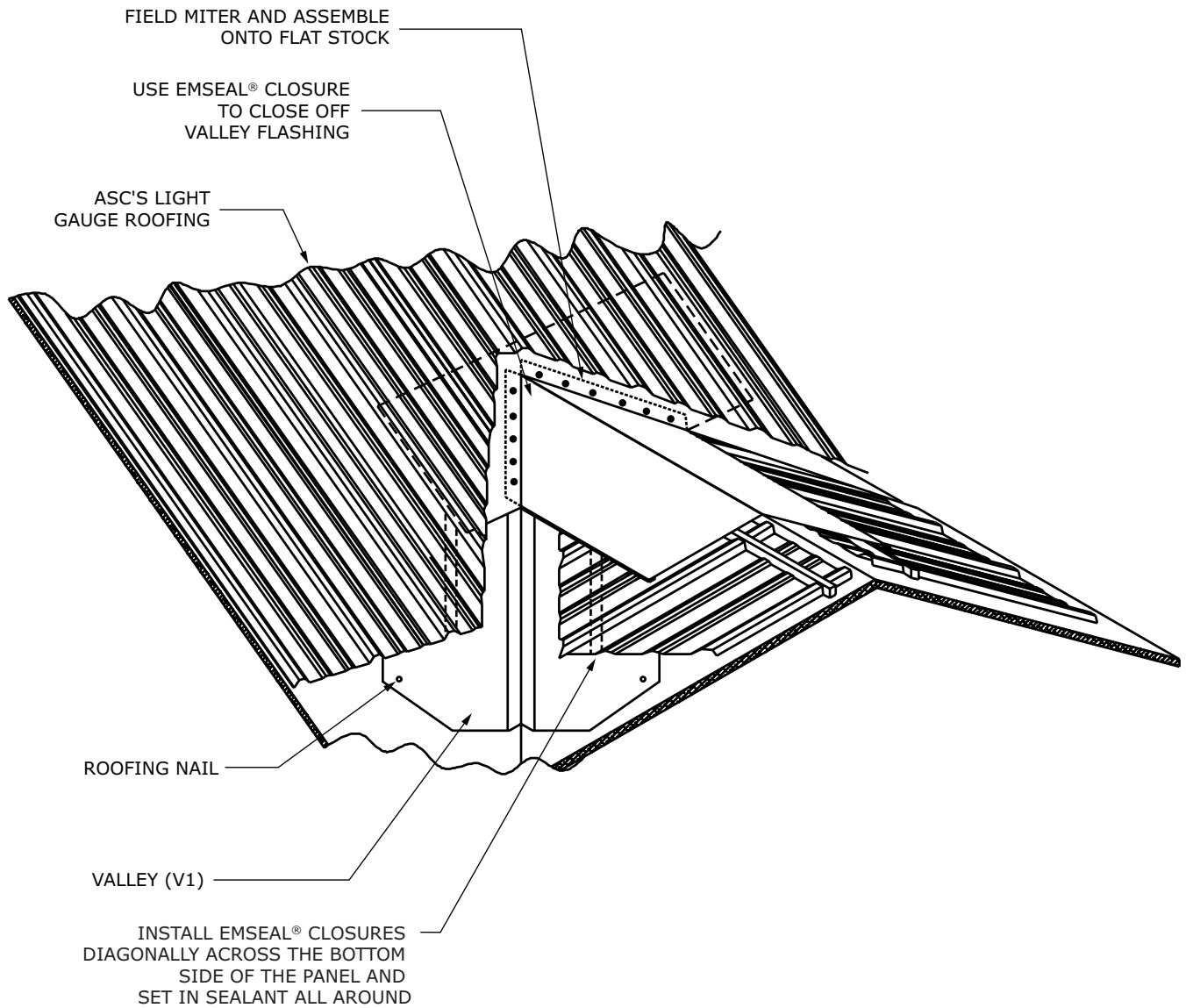

Note: Refer to Ridge and Valley installation details within this guide for further clarification on those areas.

Metal Roofing Panels

Installation Guide for Delta Rib™, Delta Rib™ III, Nor-Clad®, Strata Rib® & 2½" Corrugated



Panel End Lap

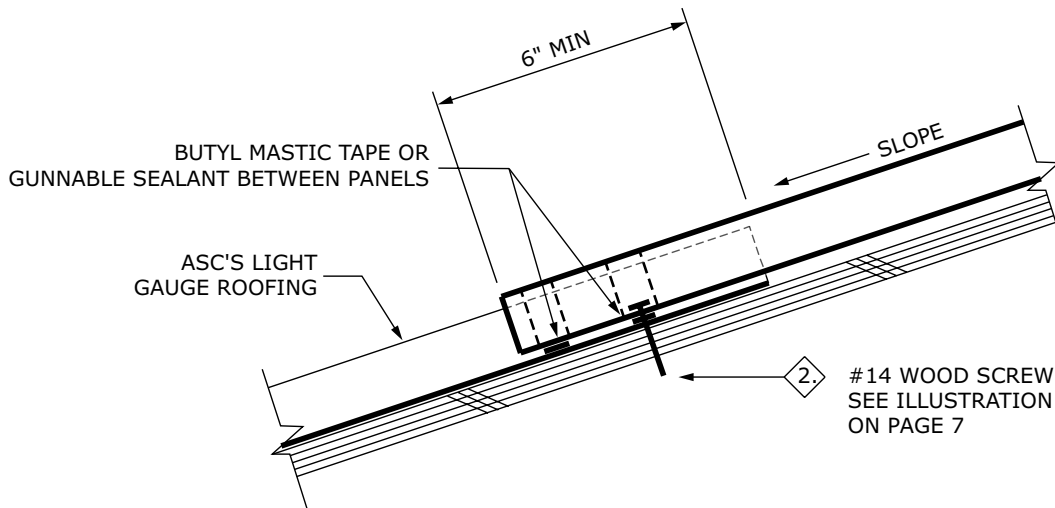

Long Panel End Lap

For panels 28 ft. or longer

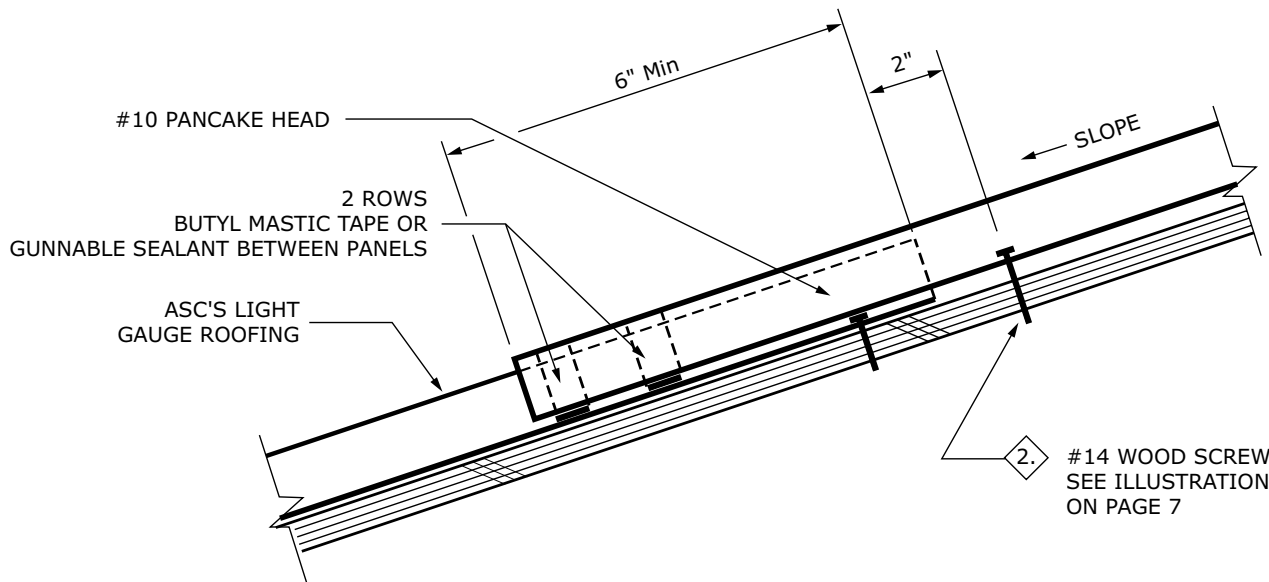

Note: Use this detail so that panels can expand and contract independently.

Sealing End Laps & Lapping the Hems

Typical Flashing Lap

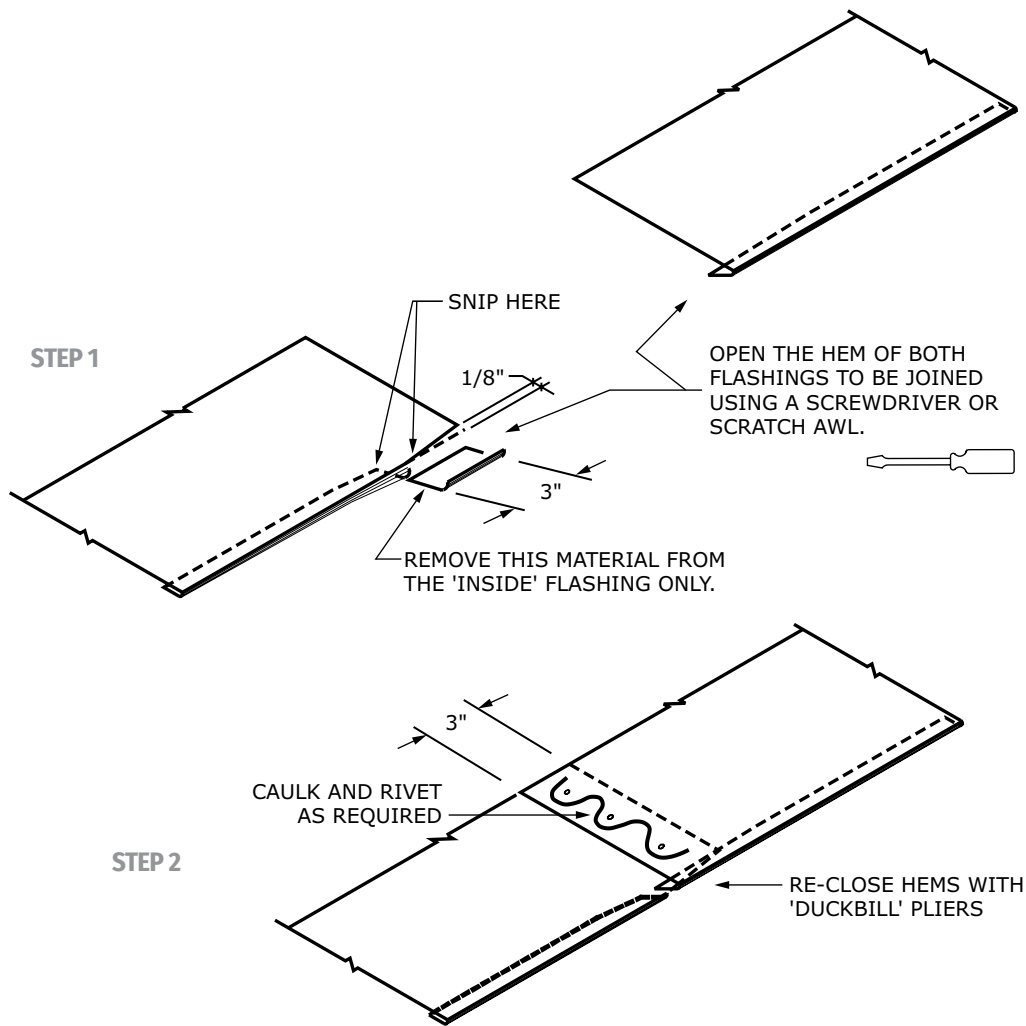

Note: Flashing expansion joints may be required for long flashing runs (i.e. 40 ft. +).

Metal Roofing Panels

Installation Guide for Delta Rib™, Delta Rib™ III, Nor-Clad®, Strata Rib® & 2½" Corrugated



Wall Details

Window/Door Trim Corner

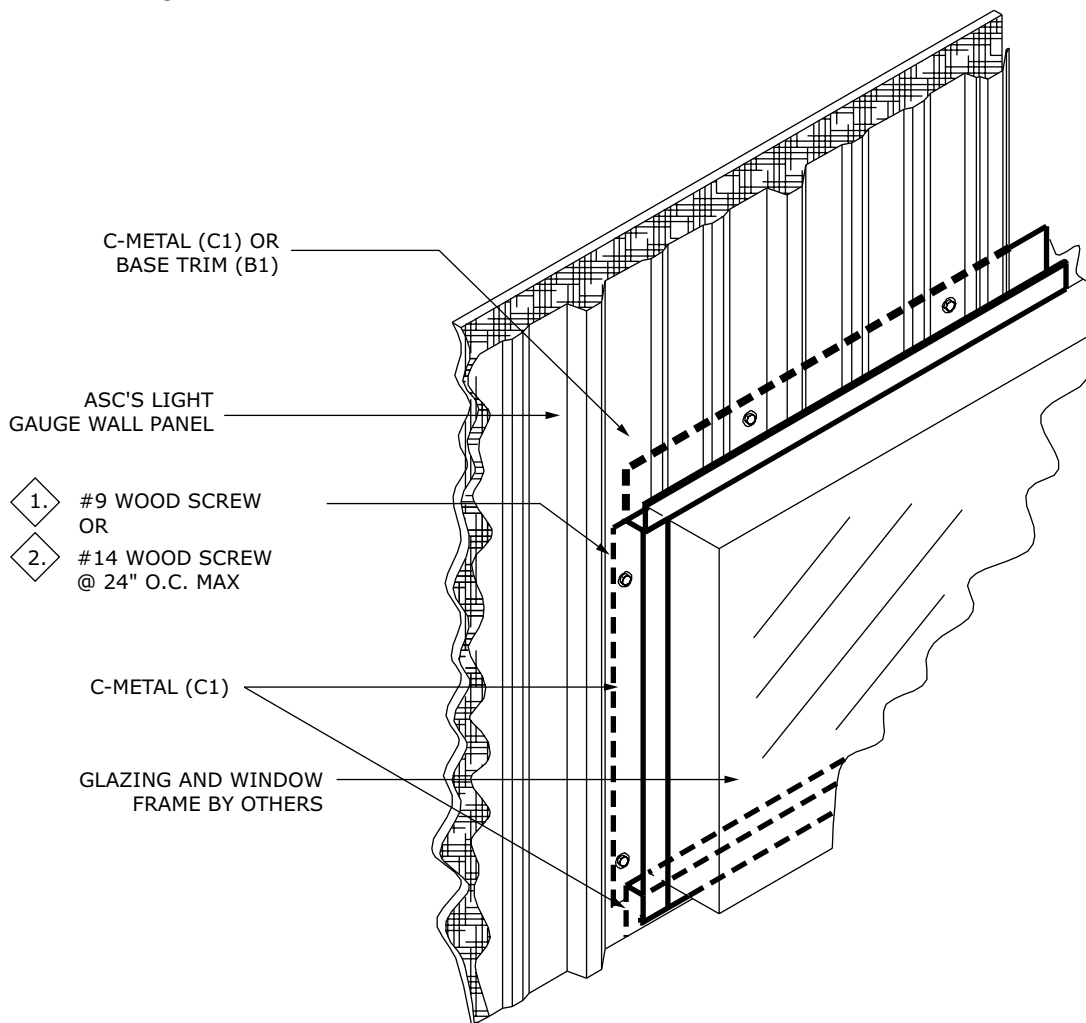
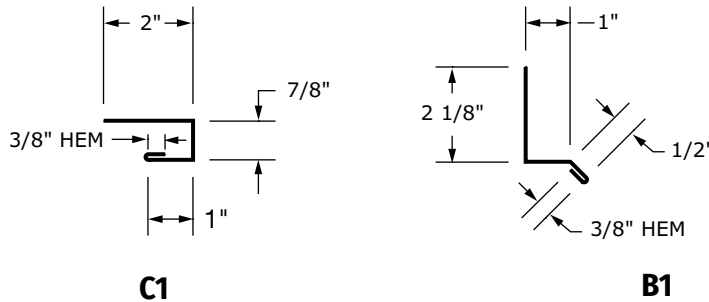

Procedures

- When installing metal roofing panels, “B1”, the Drip Flashing, is preferred at the head.
- A horizontal cut, 1" long, needs to be made in the wall panel at the intersection of the jamb and head trim. Extend the head trim into this slot, allowing for proper drainage to the outside of the building.
- Concealed neoprene closures left out for clarity. Place inside closure behind panel at C-metal (C-1) or base trim (B1)

Note: “C1” is shown at head location. “B1”, Base Trim, can also be used.

Wall Details
Top and Bottom Trim

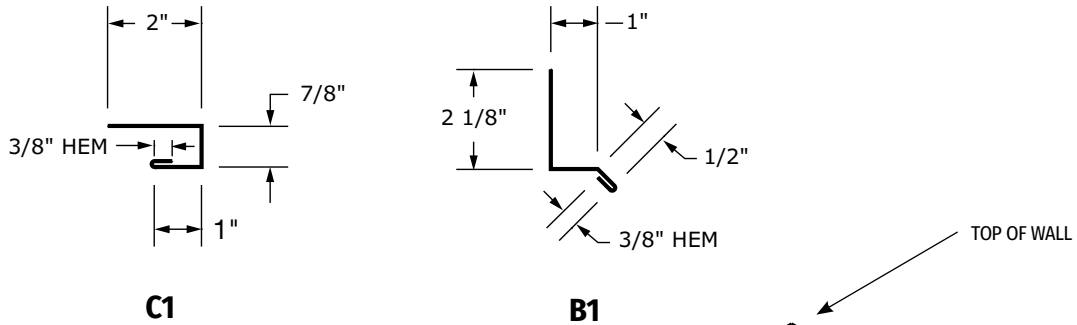

- 3. #12 x 3/4" STITCH SCREW
OR
- 4. #14 x 7/8" SELF DRILLER
@ EACH RIB OR EVERY 8" O.C.
FOR 2-1/2 CORRUGATED

C-METAL (C1)
(If required)

- 1. #9 WOOD SCREW
OR
- 2. #14 WOOD SCREW
@ 24" O.C. MAX

BASE TRIM (B1)
(If required)

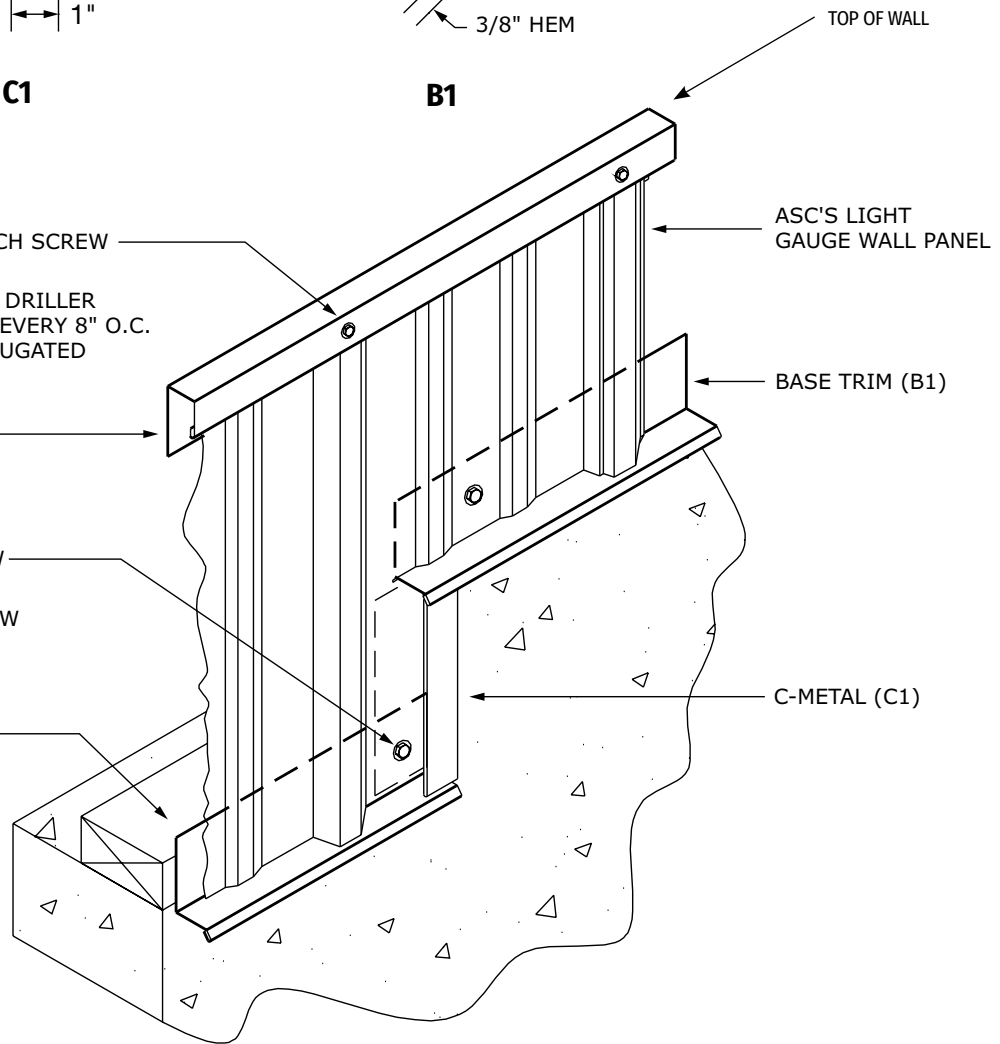

Procedures

- Open framing shown. If installing over plywood/OSB, use a #14 wood screw for panel attachment.
- Concealed neoprene closures left out for clarity. Place bottom closure behind panel at base trim and top closure on top of sheet behind "C1" at panel top, if required.

Metal Roofing Panels

Installation Guide for Delta Rib™, Delta Rib™ III, Nor-Clad®, Strata Rib® & 2½" Corrugated



Wall Details Inside Corner

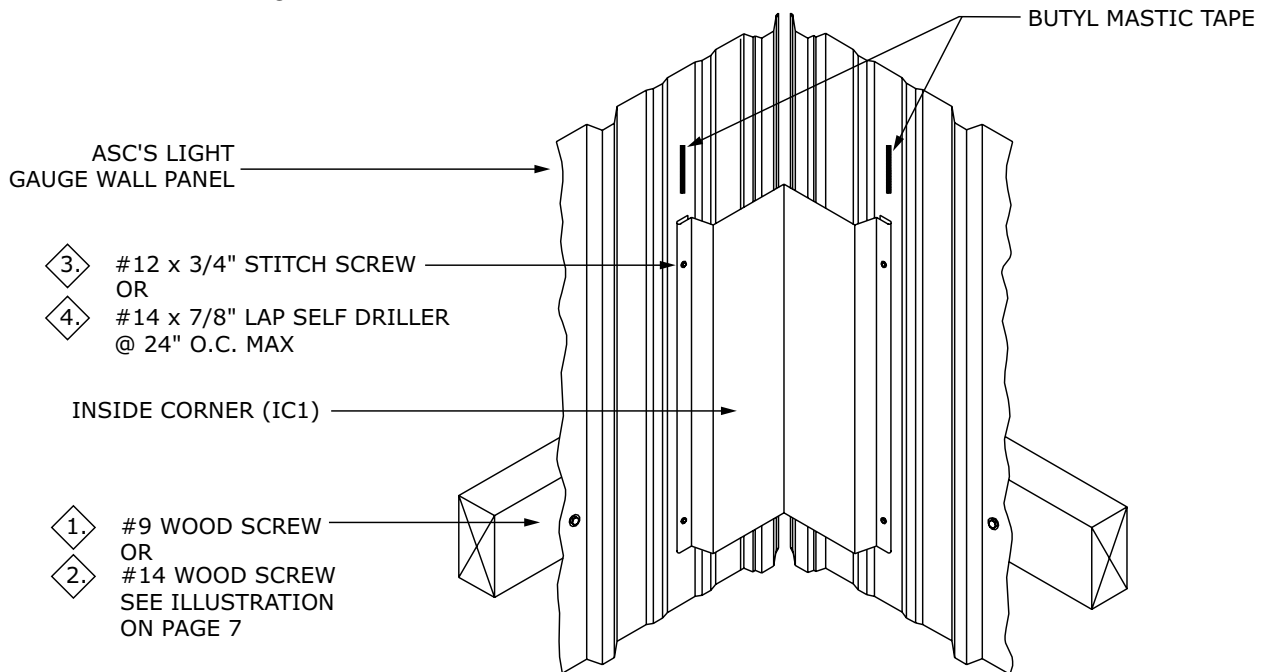
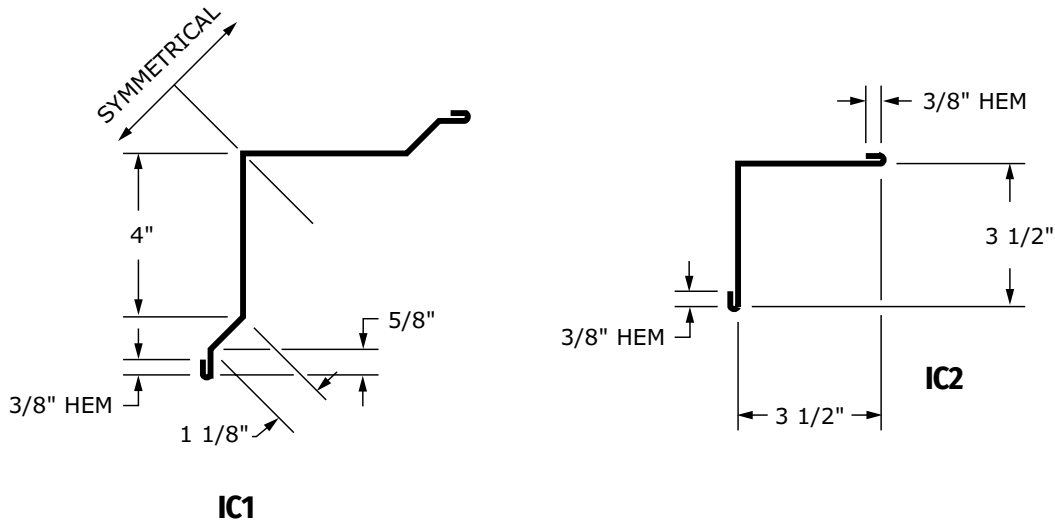

Procedures

- Open framing shown. If installing over plywood/OSB, use a #14 wood screw for panel attachment.
- Nor-Clad® panel shown. When installing other metal roofing panels, use the Universal Inside Corner "IC2".
- In many situations, the last panel installed at the corner will require that the panel be cut in width. Allow the cut edge to be covered by the inside corner trim.

Wall Details
Outside Corner

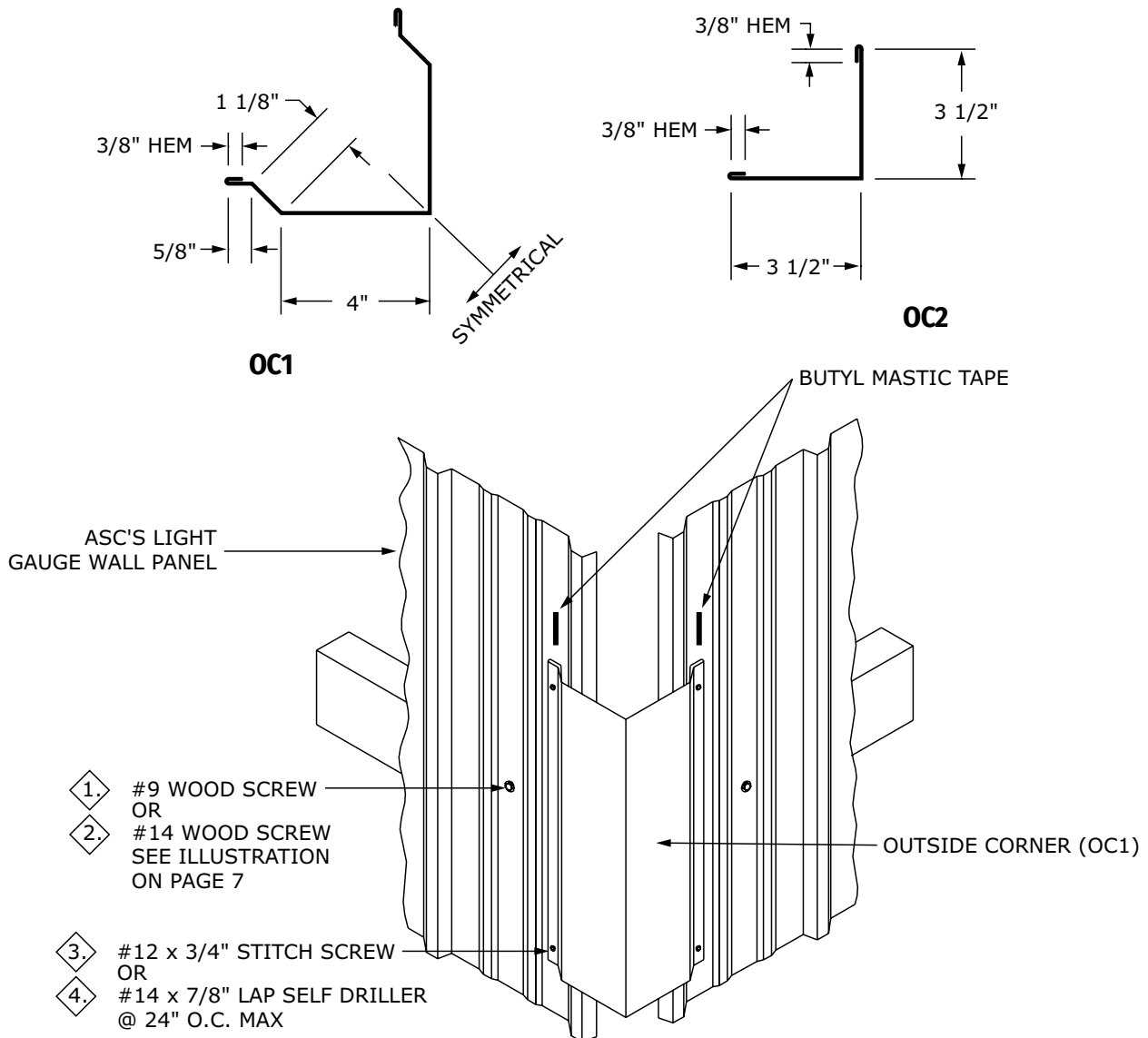

Procedures

- Open framing shown. If installing over plywood/OSB, use a #14 wood screw for panel attachment.
- Nor-Clad® panel shown. When installing other metal roofing panels, use the Universal Outside Corner "OC2".
- In many situations, the last panel on each side will project beyond the building corner, requiring the panel to be cut in width. Allow the cut edge to be covered by the outside corner trim.

Manufacturing Facilities:

Anchorage, Alaska

2441 Cinnabar Loop
Anchorage, AK 99507

West Sacramento, California

2110 Enterprise Boulevard
West Sacramento, CA 95691

Salem, Oregon

4063 Salem Industrial Drive NE
Salem, OR 97303
Customer Service Center
800-272-7023 • 503-390-7174

Spokane, Washington

4111 East Ferry Avenue
Spokane, WA 99202
Customer Service Center
800-776-8771 • 509-536-4097

Corporate Headquarters:

ASC Profiles

2110 Enterprise Boulevard
West Sacramento, CA 95691

Visit us at our website:

www.ascbp.com



All information stated in the catalog is correct at time of printing and subject to change without notice, check our website for the latest version.

© 2008-2024 ASC Profiles LLC. All rights reserved. ZINCALUME® is a registered trademark of BlueScope Steel Ltd.

Printed in the USA. 0324 web BR128